



KNX
The worldwide STANDARD
for
home and building control

www.knx.org

KNX Association International



KNX status quo

January 2017

www.knx.org

KNX is the standard

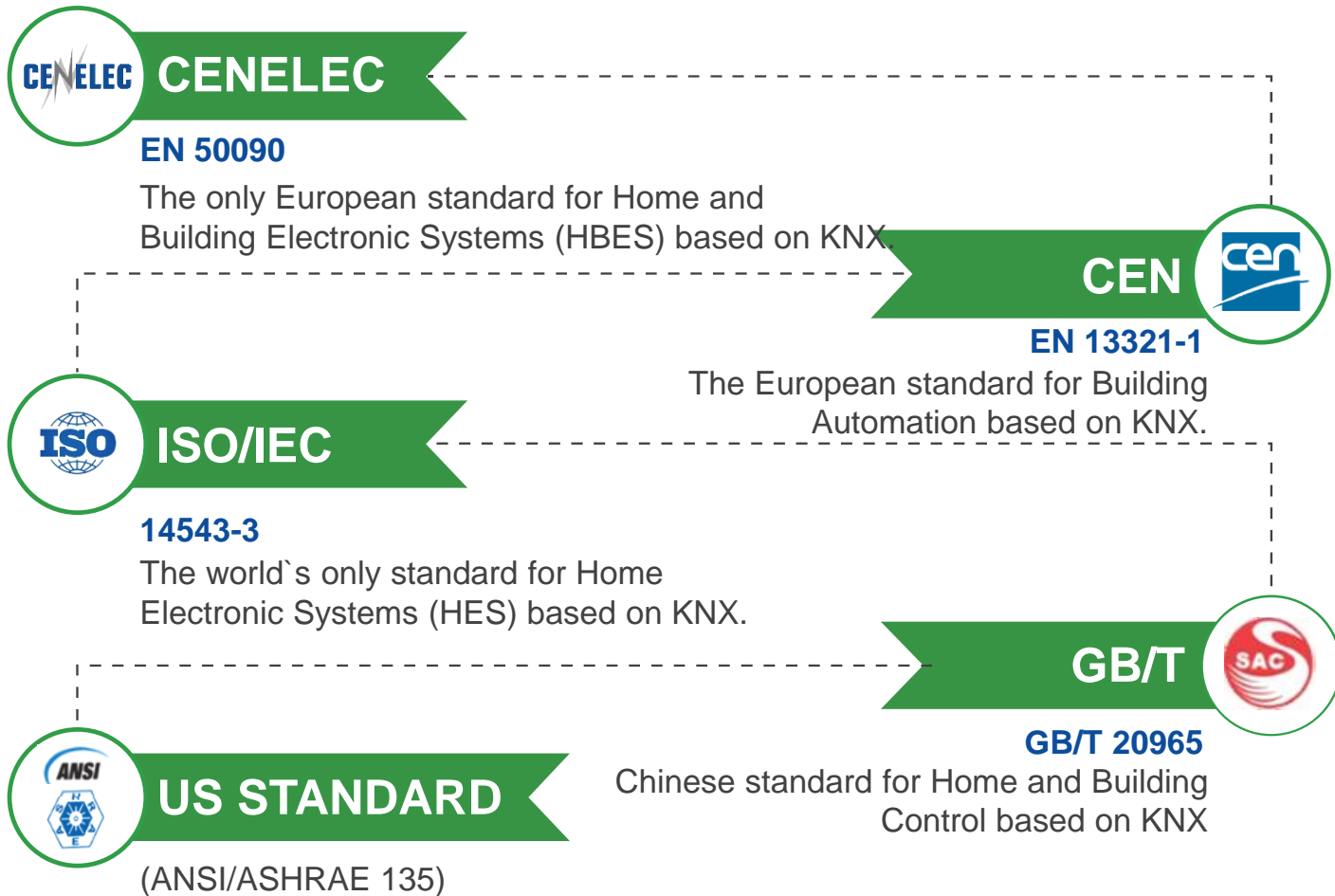

KNX is interoperable (1)

Guaranteed interoperability through neutral certification

- KNX is the only home and building control standard running global certification schemes for



Products

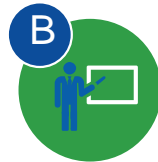

Training centres



Persons

- Product compliance is checked at neutral third party test laboratories



KNX logo guarantees interoperability between products of different manufacturers and applications

KNX is interoperable (2)

Guaranteed interoperability through neutral certification

- One PC software tool for



Design



Configuration



Diagnostics

of all KNX certified products

- Tool is independent of manufacturers, devices and applications – integrator can combine products of different manufacturers and applications in one installation



- Tool is extendable with customised apps



KNX is smart home

ETS Inside is...

- **Smart** - Finger tap instead of mouse click
- **Simple** – One tool for installers and end users
- **Safe** - No unauthorised access

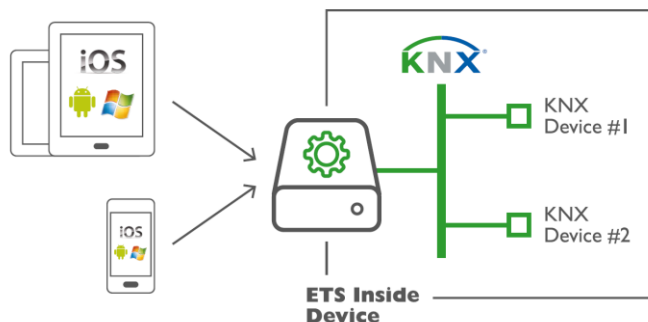
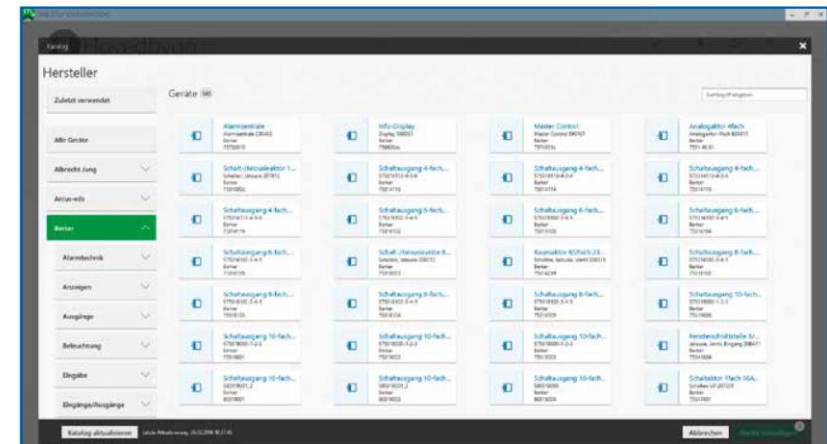

- 1 ETS Inside is part of the KNX system. Operation and ETS data are decoupled.
- 2 The easily comprehensible user interface even runs on tablets and smartphones.

KNX is fit for use in ALL applications

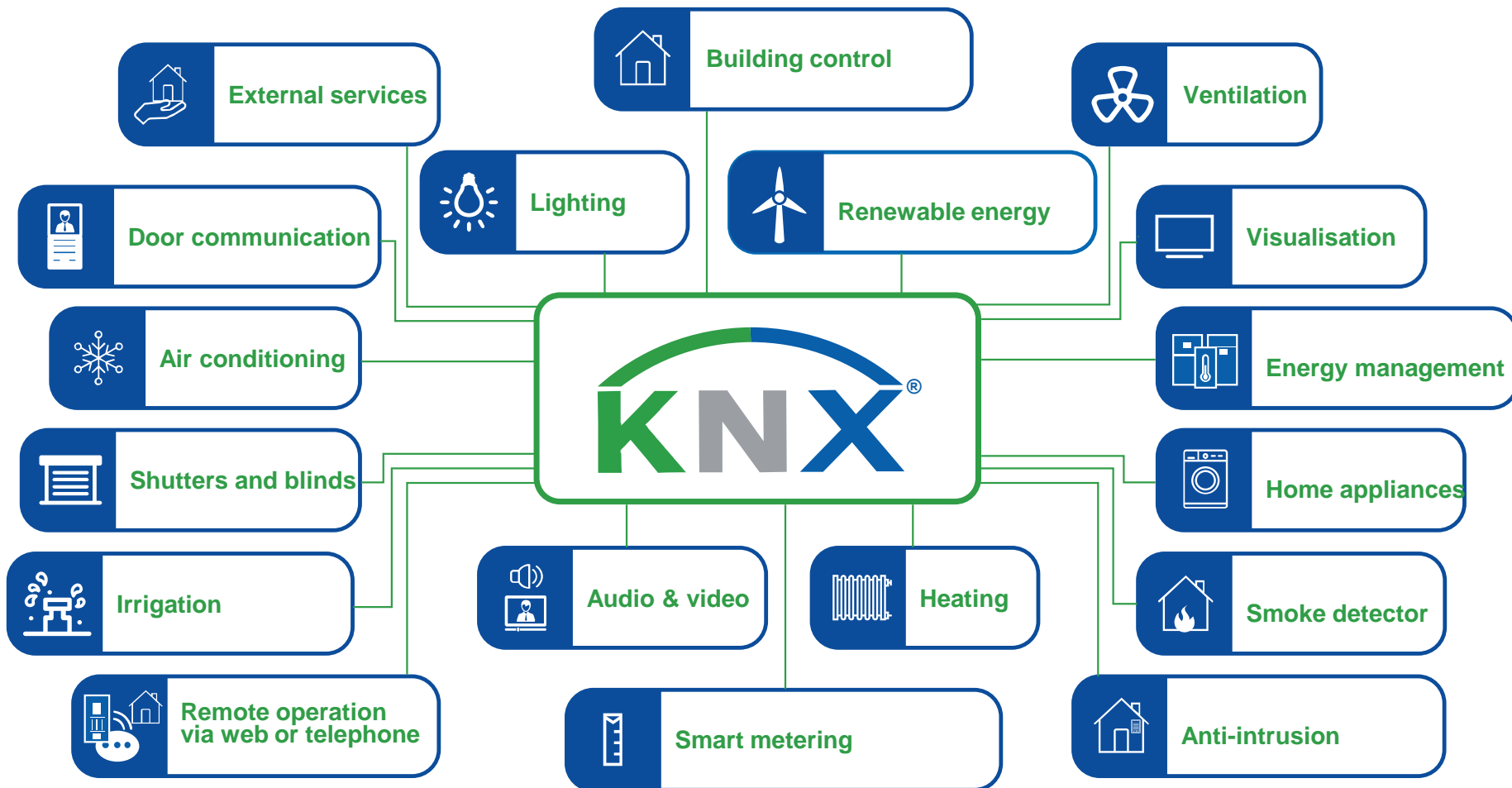

KNX is fit for use in all kinds of buildings



- New or existing buildings
- Single-family houses or large size buildings
- Easy extendable/adaptable to new requirements



KNX supports the most important transmission media



Twisted Pair

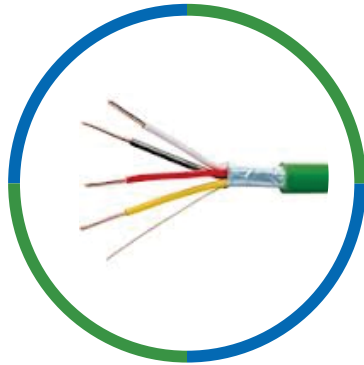

Power Line

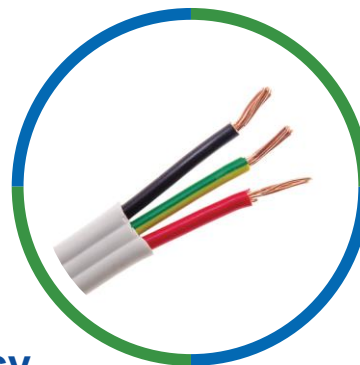

Radio Frequency



Ethernet/WIFI



KNX supports different configuration Modes



System Mode



Configuration with PC (ETS)



Prior basic course training recommended



Any size of installation



Easy Mode



Configuration without PC



No prior training necessary



Small or medium size installations

KNX is easy to couple with other systems



- KNX members offer large variety of gateways to couple to other systems

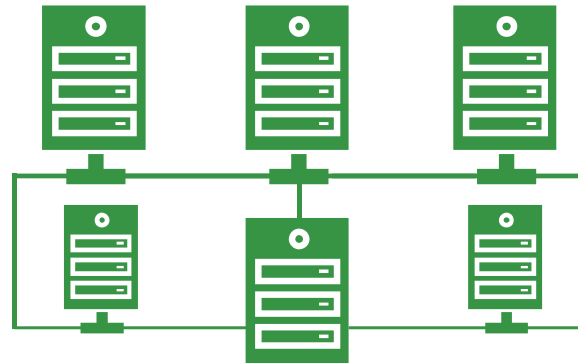

- Examples



Mapping to BACnet

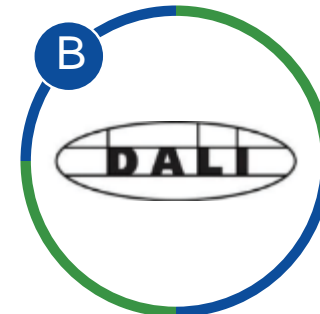

Interfacing with DALI

KNX is secure



KNX Secure uses AES128 CCM for encryption/authentication and Diffie-Hellmann for a secure key exchange.

1 KNX IP Secure

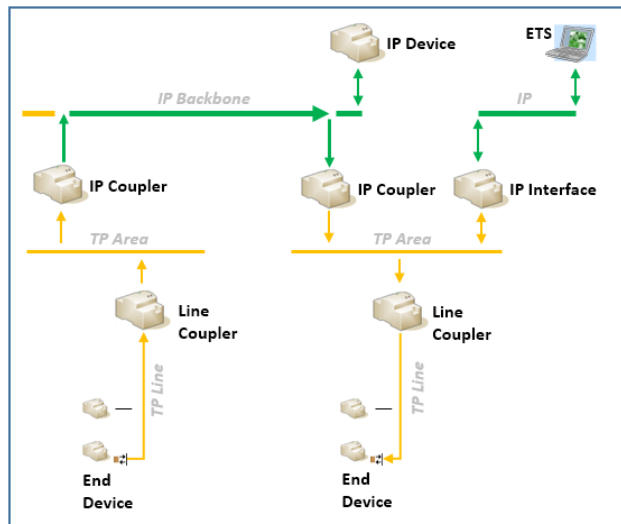

All KNX telegrams between two (or more) IP couplers are **SECURED**

2 KNX Data Secure

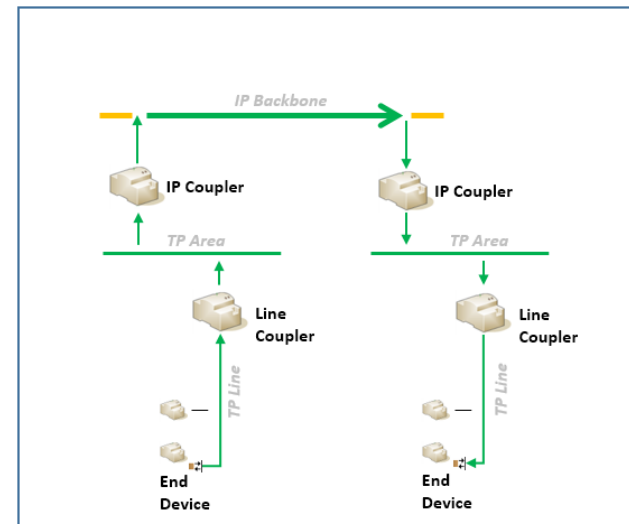

The group communication of a particular sender (one or more group objects) to another group object(s) is **SECURED**

KNX is part of Internet of Things



KNX current ecosystem

KNXnet/IP

KNX IoT 1.0

Web services

- A gateway maps the KNX project
- Using oBIX, OPC UA and BACnet-WS
- Open data exchange of values and states

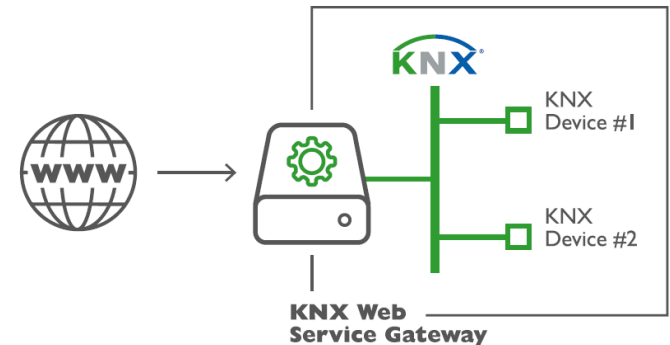

KNX IoT 2.0

2018: Plug & Play internet connected web services

KNX IoT 3.0

2020: Direct IP devices within KNX ecosystem
KNX devices sit natively on IP

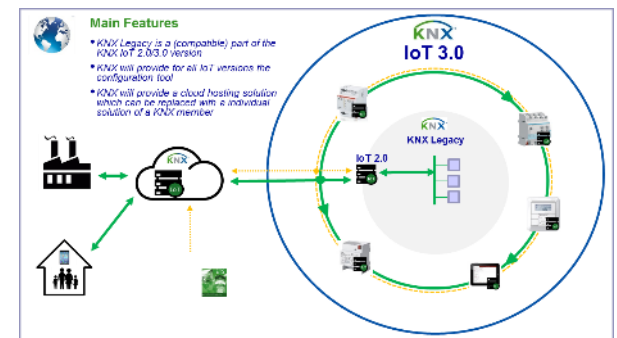

KNX IoT 4.0

> 2020: Self-learning adopting system



KNX facts and figures

January 2017

www.knx.org

405 members in 42 countries



KNX members

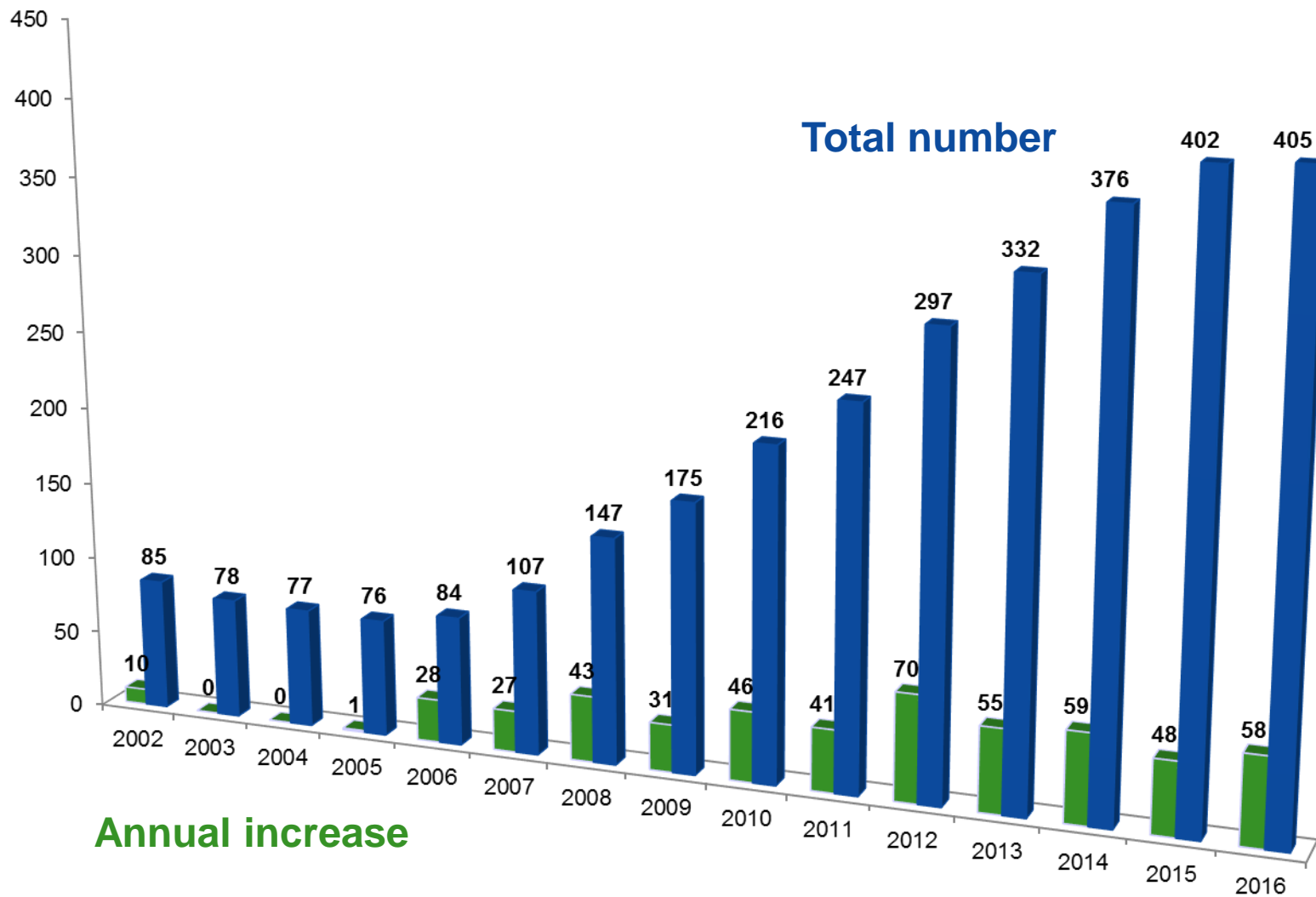

More than 7000 certified KNX products (samples of HVAC devices)

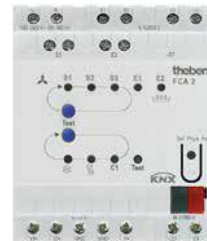

KNX facts & figures



- 405 KNX Members in 42 countries
- 7000 certified product groups
- 16 Test labs in 8 countries
- 66430 KNX Partners in 157 countries
- 400 Training Centers in 66 countries
- 20 Userclubs in 18 countries
- 44 National Groups
- 130 Scientific Partners in 33 countries
- 15 Associated partners
- ETS sold in 140 countries

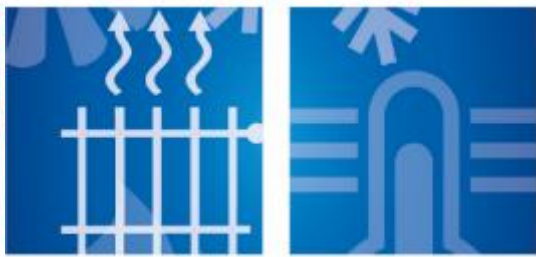

**Heating, cooling, ventilation
with KNX**

Systems and products

www.knx.org

Networking of the room automation functions



- If class A is to be achieved according to EN15232, the following is necessary:
 1. networking of energy-efficient room automation functions for all applications
 2. demand-oriented control
- KNX fulfills all technical requirements for the integration and communication of the different applications and products
- The integration of HVAC technology in home and building automation has long been part of standard KNX applications
- Currently over 70 manufacturers have registered KNX products with heating, ventilation and air conditioning applications

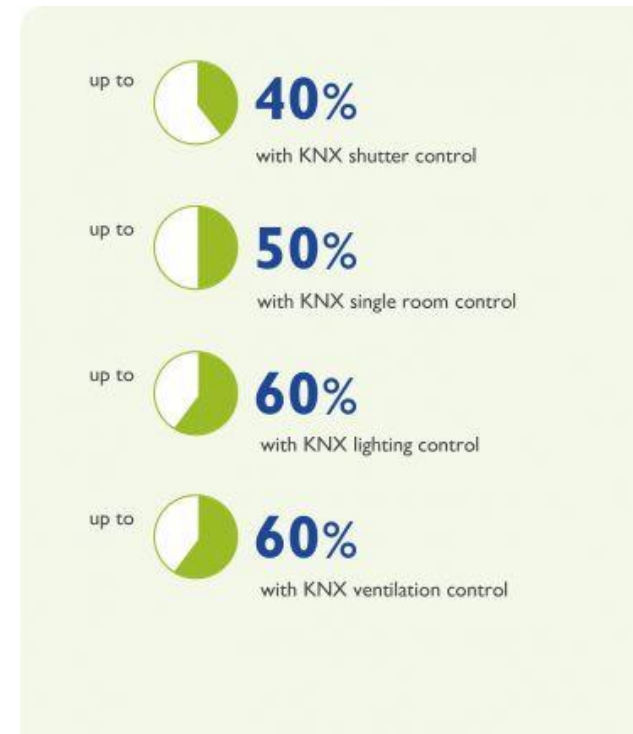

KNX has already shown in a variety of studies and projects that savings of 50 % to 60 % can be achieved through individual room control and ventilation control alone.

Individual room temperature control

Individual room temperature control offers the possibility of regulating the room temperature of a single room regardless of the temperature in other rooms.

- The current controllers are mainly complete, aesthetically sophisticated room controllers which also control all the other functions in a room.
- Some of the current controllers can also measure the CO₂ content and air humidity as well as support the heating and / or cooling operating modes.



1 Iddero: KNX 4.3" Touch Panel 2 Berker: KNX room controller with TFT display
3 Vitrum: Vitrum Clima Control 4 Basalte: Deseo temperature controller



5 Elsner Elektronik: Cala KNX Room Controller 6 MDT Technologies: Glass push button Smart II
7 ABB: ABB i-bus KNX Logic Controller ABA/S 1.2.1



8 Sauter: Room Controller ecos504/505 9 Bleu Comm Azur: realKNX Server
10 Siemens: Synco IC 11 Sinapsi: M-Bus/WM-Bus Web Server

Radiator and underfloor heating, cooling ceilings



Valves control the rate of flow in the individual heating and cooling circuits

- The triggering of the valves is normally carried out via analogue thermoelectric or motor valve drives.
- Motor valve drives with an integrated KNX interface...
 - can be very precisely positioned
 - mostly have additional intelligence and diagnostic functions
 - transfer both the current valve position and error messages via KNX



12 Insta Elektro: KNX Valve drive IB
13 Ekinex by SBS: KNX mixing actuator
14 MDT Technologies: Heating actuator

Fan coil controllers

A benefit of fan coil control is the rapid availability of thermal energy or cooling capacity. It is therefore widely used in hotels and office buildings.

- The control of the fan and the heating or cooling register is carried out via special KNX fan coil actuators in the unit while the operation is usually carried out via KNX room thermostats with extended functions and setting options.
- It is possible via KNX to separate the unit and the operation cost-effectively in terms of rooms.



15 Jung:
KNX Fan Coil Controller

16 Theben:
Fan Coil Actuator FCA 2 KNX

Interfaces to energy generation and distribution systems



With interfaces to power generation systems it is possible:

- to display the current state of their heating system using the KNX visualisation system
- to predefine setpoint values and set operating modes
- Fault signals are automatically transmitted to KNX and displayed
- As the current heat requirement in the rooms can be communicated via the KNX gateway to the heating controllers, the heat generation must be precisely matched to the current demand.



17 ISE Individuelle Software-Entwicklung: ise smart connect KNX Vaillant 18 Viessmann: Vitogate 200
19 Stiebel Eltron: Internet-Service-Gateway (ISG) 20 Bosch: Bosch Gateway KNX 10 21 Wolf: Wolf KNX interface kit

Variable volume flow controller

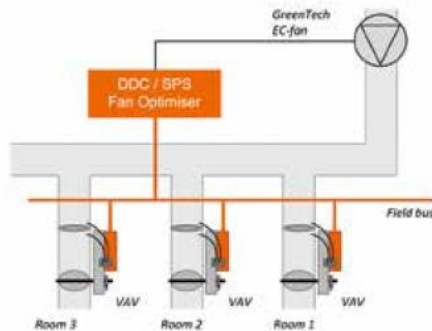

- Based on the recorded room conditions and the current air requirement, energetically intelligent and demand-controlled systems can be set up with KNX.
- A central control unit permanently monitors the flap positions of the individual VAV boxes via KNX. If the flaps eliminate excessive inlet pressure, this is reduced.
- The aim is to operate the system with the lowest possible pressure loss.

22 Belimo Automation: VAV controller and actuators
 23 Maico: KNX ventilation units with HR



Room air control and interfaces to ventilation systems



- In addition to the baseline values, the values for the room temperature, air humidity and carbon dioxide content measured by the KNX individual room controllers and air quality sensors can be transferred via the KNX interfaces to the ventilation system and taken into account during the control.
- In the other direction, the ventilation system transfers status signals to KNX which for example signal the necessary replacement of ventilation filters.



24 arcus-ed: KNX LUNOS-CONTROL4
25 Busch-Jaeger: KNX room temperature controller with CO₂ sensor
26 Hugo Müller: KNX air quality sensor
27 Vallox: VALLOX MV KNX bus module

Interfaces to distributed air conditioning systems



- The interfaces to the air conditioning systems are versatile. In addition to a few standardised interfaces, the manufacturers use a variety of proprietary hardware and protocol solutions.
- Special KNX gateways enable the integration of almost all the air conditioning devices into KNX.



28 Weinzierl Engineering: KNX Modbus Gateway 886

29 Astrum: VFACE – Ultimate VRF Interface

30 Pulsar: THINKKNX BRICKBOX

31 Intesis: IntesisBox Universal KNX AC Gateway

Over 7,000 certified KNX products

cover all the applications of heating,
ventilation and air conditioning

The KNX worldwide standard

thus offers the best requirements to improve the
energy efficiency of buildings.

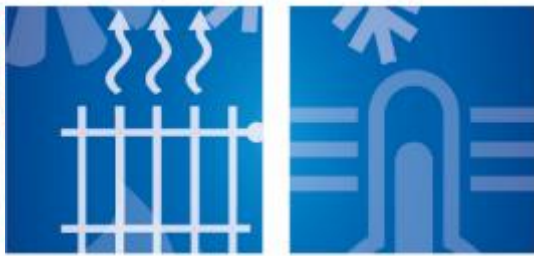

**Heating, cooling, ventilation
with KNX**

Project examples

www.knx.org

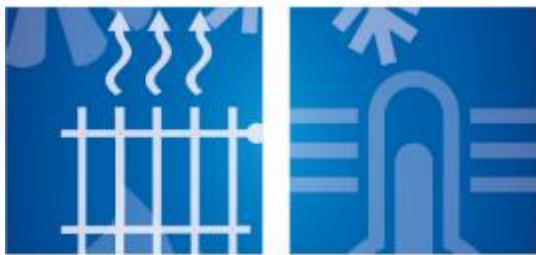

www.knx.org

**Heating, cooling, ventilation
with KNX**

**Example 1
Integration of heating
systems**

Integration of heating systems

Connection between KNX and heating systems creates new possibilities

In combination with the Vaillant multimATIC 700 heating regulator, the ise smart connect KNX Vaillant and the ise adapter, you can now integrate the heating system, ventilation system and/or the yield and consumption values in building scenarios, visualisation and facility management systems.

- **Information about the heating system**
Display of maintenance modes, error messages, date and time, outside temperature, system status
- **Display yield and consumption values**
Output values of solar system and heat pump, consumption values of water heating and heating (electricity, gas)

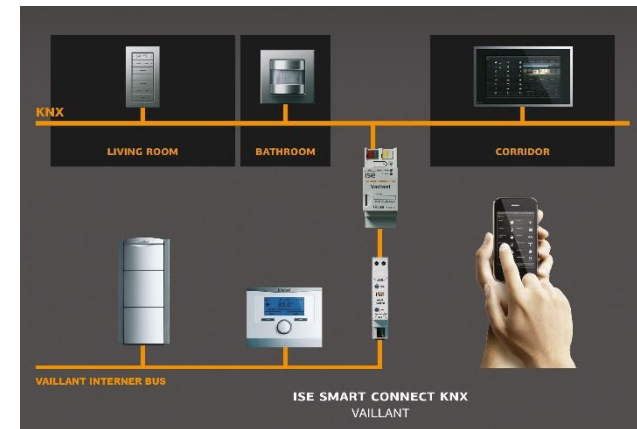

A new building near Dortmund

Integration of heating systems

Possible application scenarios:

- Control the heating on demand**
 Times and setpoints for heating and domestic hot water can be configured and updated quickly and easily via a visualisation or any other sensor device.
- Automatic ventilation**
 The ventilation system starts automatically when leaving the house so the house owner returns to a pleasant room climate.
- Short-term, extended night mode**
 The automatic night operation mode can be delayed at your fingertips so your guests also feel comfortable later in the evening or even early in the morning.

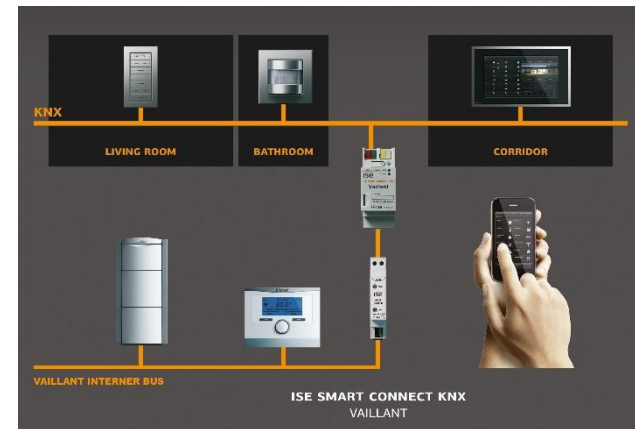

A new building near Dortmund

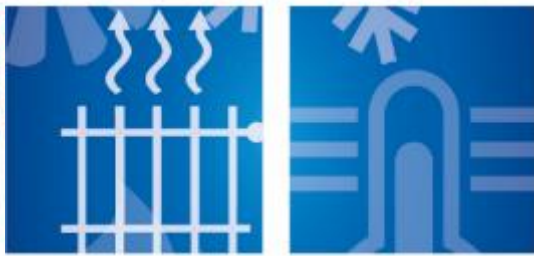

www.knx.org

**Heating, cooling, ventilation
with KNX**

**Example 2
A thinking home**

A thinking home

Intelligent home automation with KNX

- All components of home automation, such as lighting, blinds, heating and room temperature control, window contacts, weather station, etc. are networked via KNX and can be centrally controlled.
- Functional examples:
 - the blinds close when the TV is switched on
 - the letterbox reports when the post has been delivered
 - the socket with an iron plugged in switches off when nobody is in the room

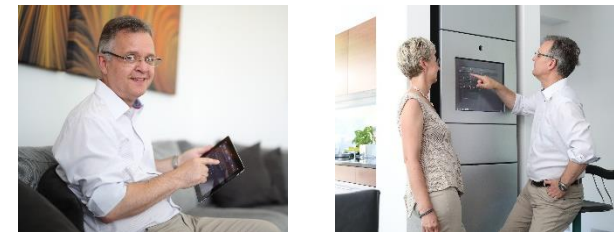

The “smarthouse213” of Ute and Matthias Schmidt from Coburg (Germany)

The fact that the heating system supplies heat as required independently of the outside temperature, helps save energy. “Demand-based heating works better with KNX 10 than before, as the valve position of the radiators and the exact room temperature are now reported to the heat generator. The actual temperature can thus be compared with the desired temperature and the boiler ‘knows’ whether it should heat or not,” Matthias Schmidt explains.

A thinking home

Buderus heating system supplies heat as part of KNX home automation

- The Buderus heating system is integrated into the home automation system via the KNX 10 gateway
- The single-room control unit allows the desired temperatures to be set manually for individual rooms.
- When open windows are detected, the room temperature control unit receives this information, switches to frost protection mode and closes the radiator valves.
- The Buderus heat generator is informed that no heat is needed and stops heating.

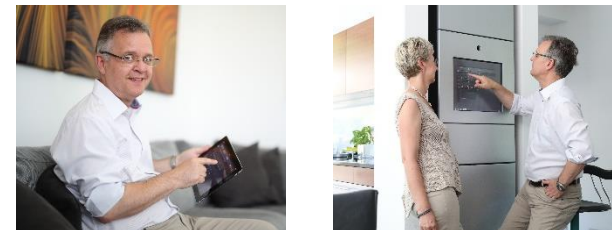

The "smarthouse213" of Ute and Matthias Schmidt from Coburg (Germany)

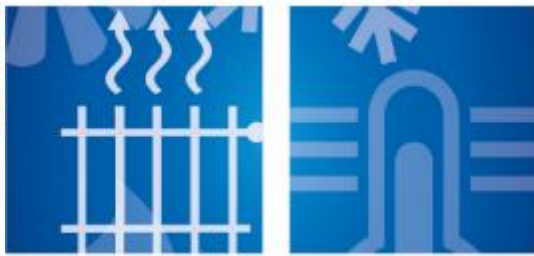

**Heating, cooling, ventilation
with KNX**

**Example 3
Energy plus fresh air**

www.knx.org

Energy plus fresh air

Intelligent networking of regenerative energy systems

- As a result, the building produces more energy than consumed for heating the building, heating the drinking water, ventilation technology and household usage (“energy-plus house”)
- A touchscreen display visualises the setup and interplay of the energy system composed of photovoltaics, heat pump, geothermal heat and controlled ventilation.
- The building technology which has been refined for maximum energy efficiency and optimum indoor air hygiene saves energy costs and avoids emissions.

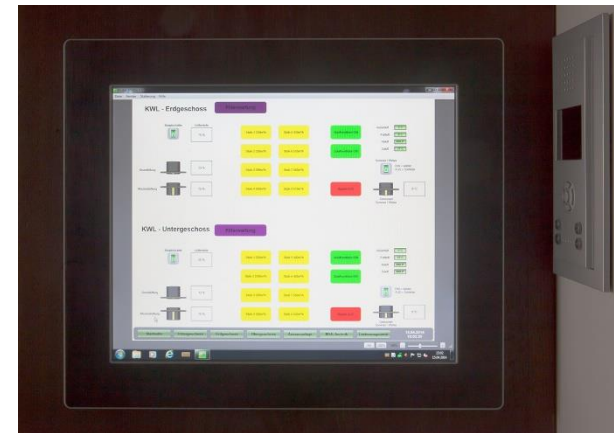

Construction of a residential house in Oberbayern (Germany)

Energy plus fresh air

Ventilation and air conditioning

- Two ventilation systems of the type Vallox ValloPlus 800 SE with KNX interface supply the rooms with filtered and preheated fresh air.
- Heat exchangers transfer up to 90% of the thermal heat from the extracted air to the incoming air.

Control over energy consumption and domestic technology

- A total of 22 KNX sensors installed in the heat generation and distribution system record the room and medium temperatures as well as the flow rates and air flow volumes.
- With the KNX visualisation, you always have an overview of the system.

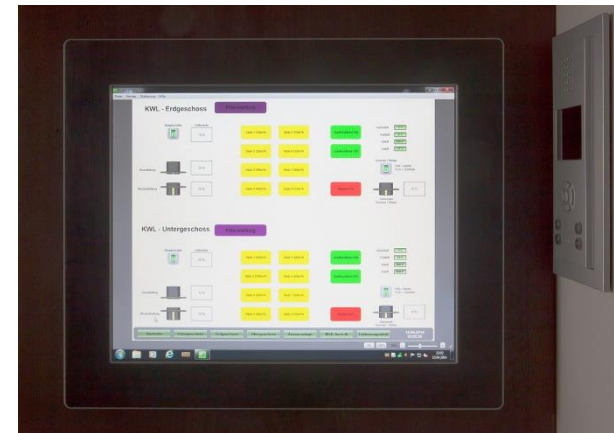

Construction of a residential house in Oberbayern (Germany)

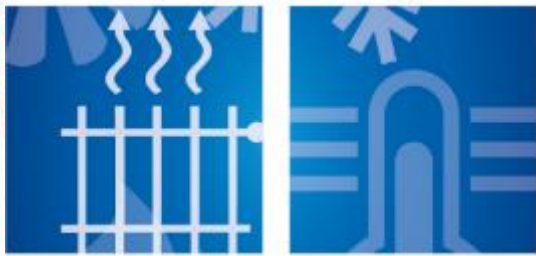

www.knx.org

**Heating, cooling, ventilation
with KNX**

Case studies

Overview of case studies

- Case study 1:** Control and monitoring of the system functions of an HVAC device
- Case study 2:** Control and monitoring of temperature
- Case study 3:** Visualisation of HVAC relevant parameters
- Case study 4:** Optimisation for optional heat pump power consumption
- Case study 5:** Heat pump power consumption forecast

Case study 1 - Control and monitoring of the system functions of an HVAC device



The display and remote control of the operating modes (comfort, standby, night reduction) for the system functions (heating, cooling, ventilation and hot water) of a generator.

Case A: The user toggles the operating state via his smartphone.

Case B: The user starts the one-time heating of the hot water before showering.

Case study 1 - Control and monitoring of the system functions of an HVAC device



KNX solution for case A

Selection of the operating mode

The user has different options depending on the system configuration:

1. To set the operating mode centrally on the power generation system. The system affects the respective heating circuit (e.g. one floor).
2. To set the operating mode separately for each room via the visualisation using individual room temperature control.

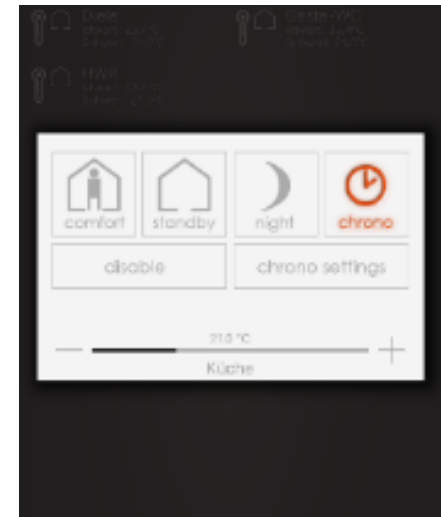

Photo: ThinKnx

The setting under point 1 has the primary function.

Case study 1 - Control and monitoring of the system functions of an HVAC device



KNX solution for case A

1. The default operating mode is only carried out on the heat / cooling generator via a heating / cooling circuit with a corresponding feedback signal.

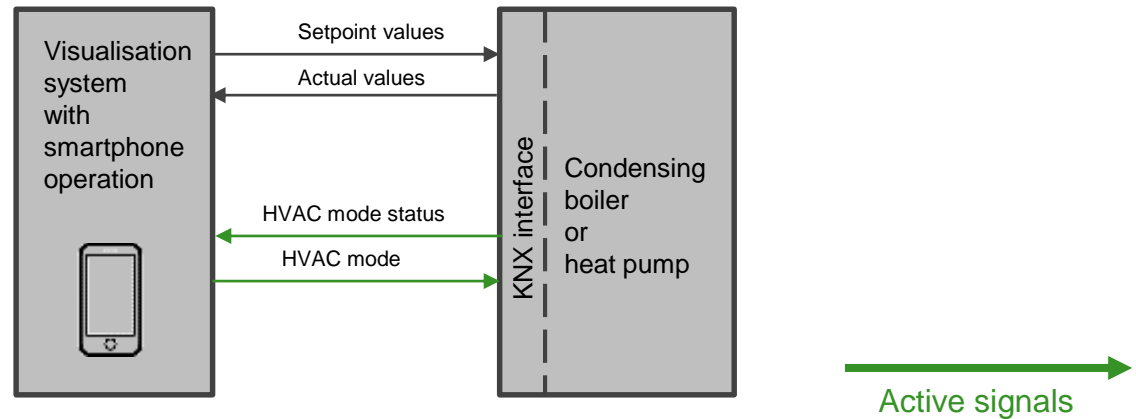

Selection and feedback of operating modes via HVAC mode, 1 byte / DPT 20.102 or 1 bit / DPT 1.00x

For example for a heat pump control:

- 0: Auto
- 1: Comfort
- 2: Standby
- 3: Economy
- 4: Building protection

Case study 1 - Control and monitoring of the system functions of an HVAC device



KNX solution for case A
 2. The default operating mode is carried out primarily at the heat / cooling generator as well as per room on the individual room thermostats. Both the room thermostats and the heat / cooling generators send a feedback signal to the visualisation about the respective status.

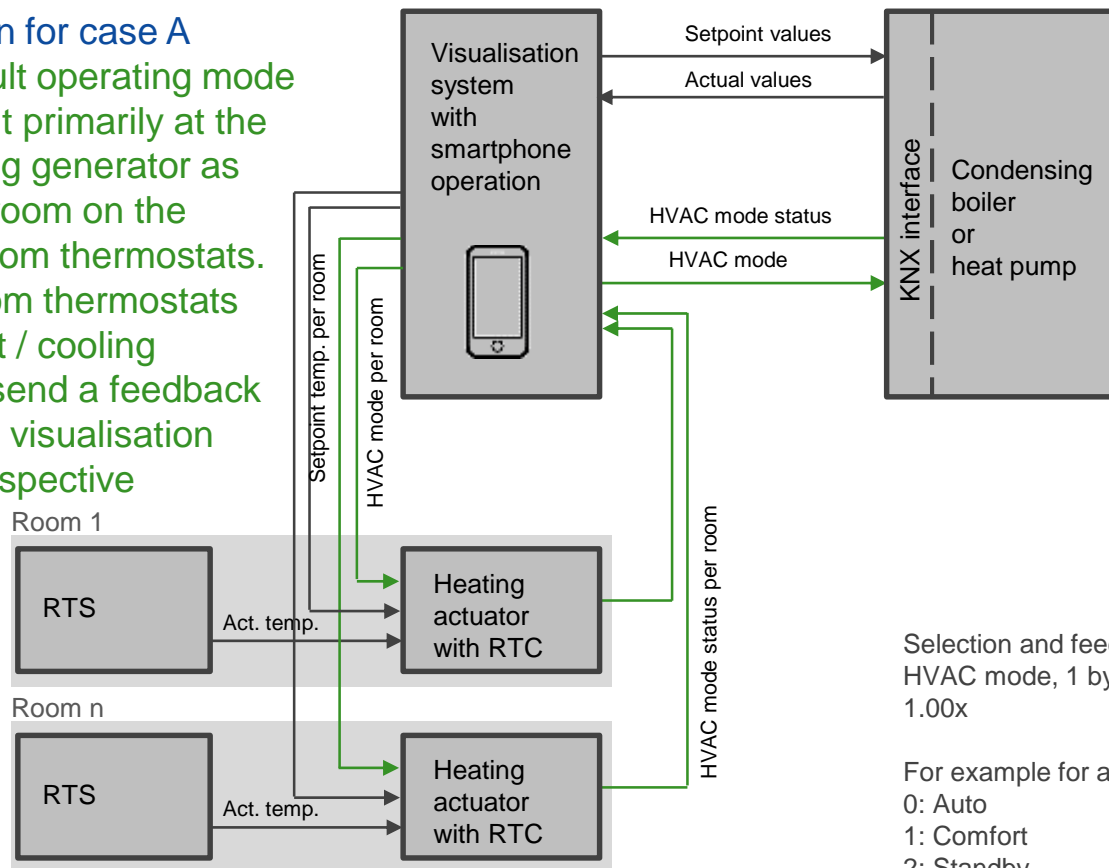

Selection and feedback of operating modes via HVAC mode, 1 byte / DPT 20.102 or 1 bit / DPT 1.00x

For example for a heat pump control:

- 0: Auto
- 1: Comfort
- 2: Standby
- 3: Economy
- 4: Building protection

RTS: Room temperature sensor
 RTC: Room temperature controller

Case study 1 - Control and monitoring of the system functions of an HVAC device



KNX solution for case B Domestic water heating

The one-time heating of the hot water e. g. via night mode, is triggered via a 1 bit command.

The status can be queried at the same object or a separate status object.

Alternatively, a temporary increase of the setpoint temperature of the hot water is possible.

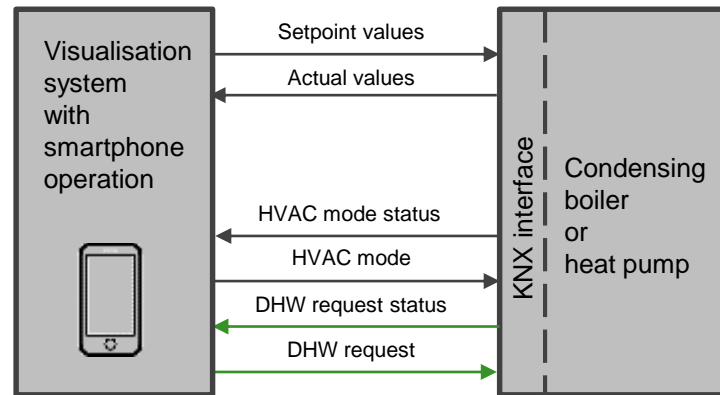

One-time domestic hot water

1 bit, DPT 1.00x

Active signals

Case study 2 - Control and monitoring of temperatures



The display of actual and setpoint temperatures of rooms, zones / heating circuits as well as the remote control of setpoint temperatures and the optional creation of setpoint temperature time profiles are among the standard functions of an individual room temperature controller.

Case A: The user sets the setpoint temperature from 19°C to 21°C.

Case B: The user would like the room temperatures to be displayed via a smartphone.

Case C: An energy manager optimises the inlet temperature of a heating circuit / zone using the predefined room temperatures.

Case D: The user configures time profiles so that the corresponding rooms have achieved the comfort temperature at the time of usage.

Case study 2 - Control and monitoring of temperatures



KNX solution for case A Changing setpoint temperature from 19°C to 21°C

An individual setpoint value can be predefined for each room by the individual room thermostat via the visualisation.

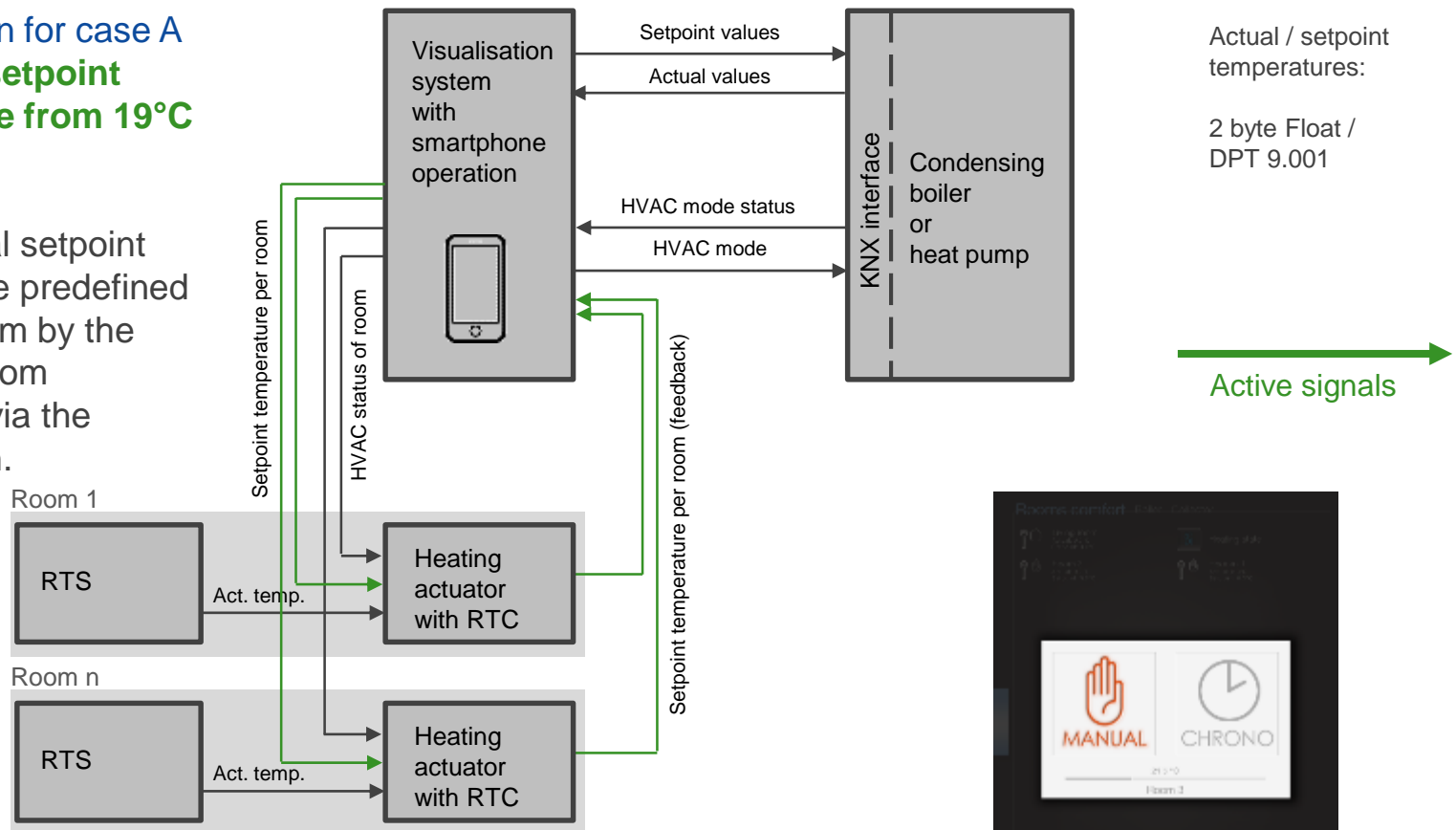

Actual / setpoint temperatures:

2 byte Float / DPT 9.001

Active signals



photo: ThinKnx

RTS: Room temperature sensor
RTC: Room temperature controller

Case study 2 - Control and monitoring of temperatures



KNX solution for case C For demand-based control, an energy manager optimises the energy consumption

The valve drives send the valve position per room to the energy manager which calculates the optimum inlet temperature on the basis of the current valve positions.

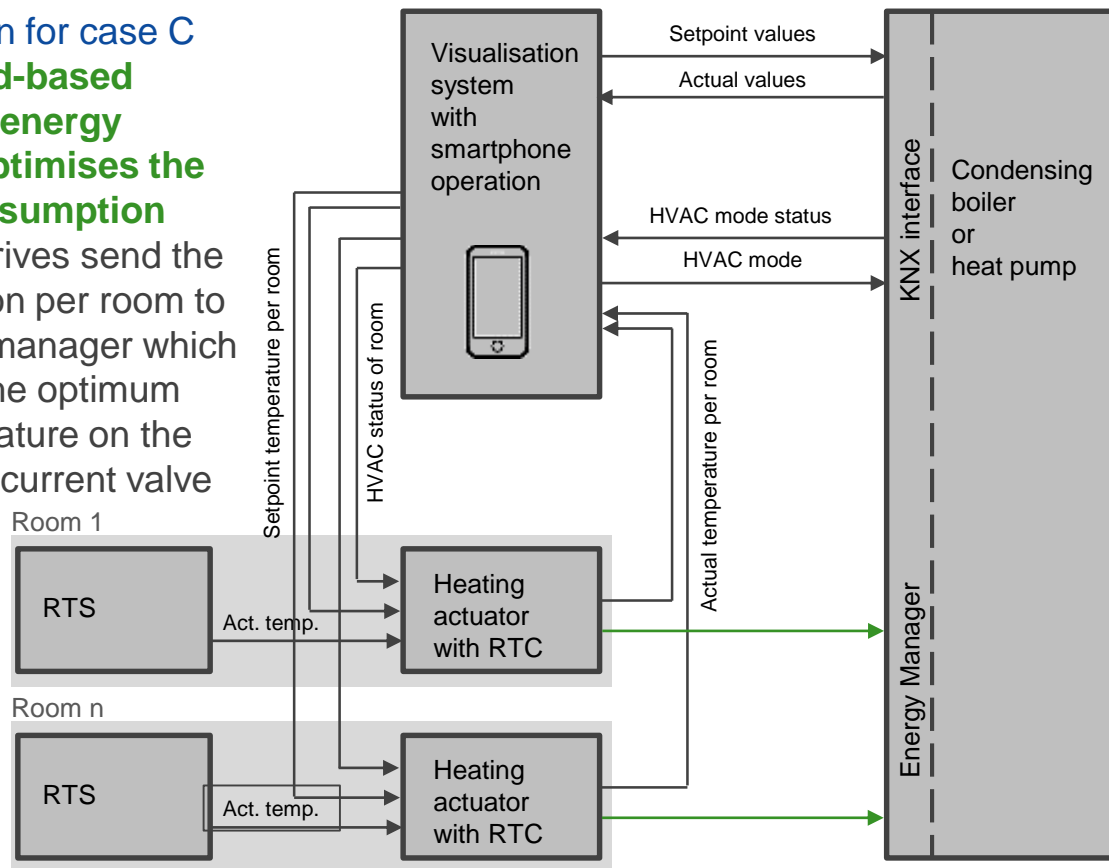

Actual / setpoint temperatures:
Value_temp
2 byte Float /
DPT 9.001

Valve lift:
Percent (0..100%),
1 byte, DPT 5.001

Active signals

RTS: Room temperature sensor
RTC: Room temperature controller

Case study 2 - Control and monitoring of temperatures



KNX solution for case D

The user configures time profiles

Individual setpoint values can be preassigned for each room for individual room temperature control. The profile data is stored in the visualisation system.

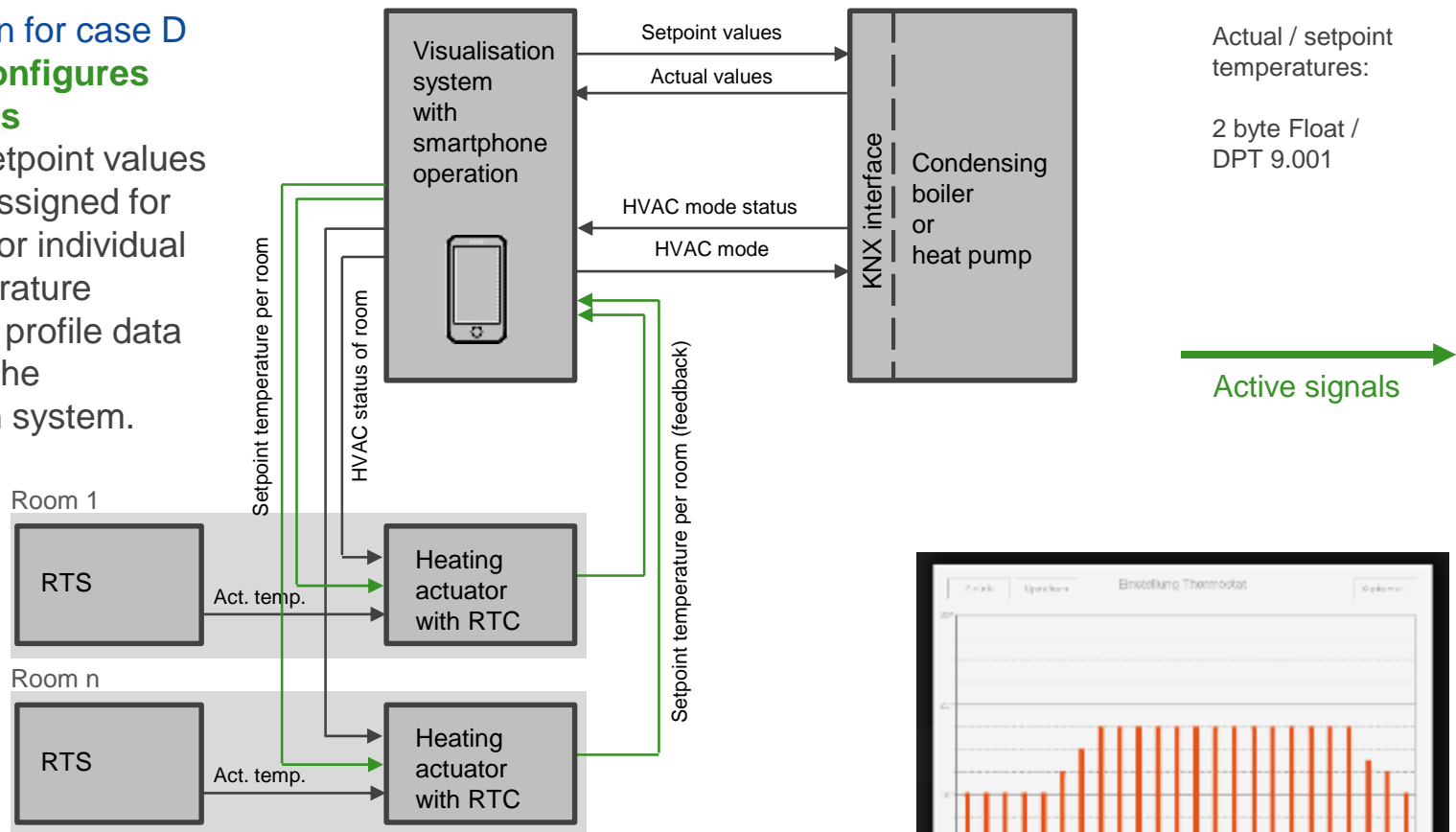

Actual / setpoint temperatures:

2 byte Float /
DPT 9.001

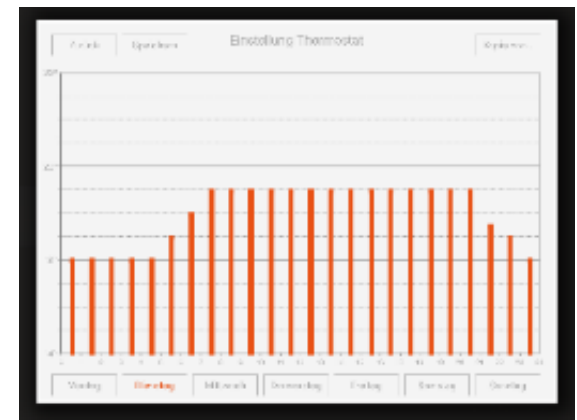

photo: ThinKnx

Case study 3 - Visualisation of HVAC-related parameters



Display of HVAC-specific parameters

- Case A:** The user would like the power consumption of HVAC devices to be displayed.
- Case B:** The user would like the operating state (normal operation, faults, service requirements ...) to be displayed via smartphone.
- Case C:** The next service interval should be indicated to the user.

Case study 3 - Visualisation of HVAC-related parameters



KNX solution for case A Power consumption of HVAC devices

Current heating controllers mainly make the energy consumption available as an absolute value on the KNX:

- electricity for heating
- electricity for hot water
- gas for heating
- gas for hot water

The energy consumption values are prepared in the visualisation system and displayed as:

- diagrams
- absolute values
- daily, weekly, monthly or annual values

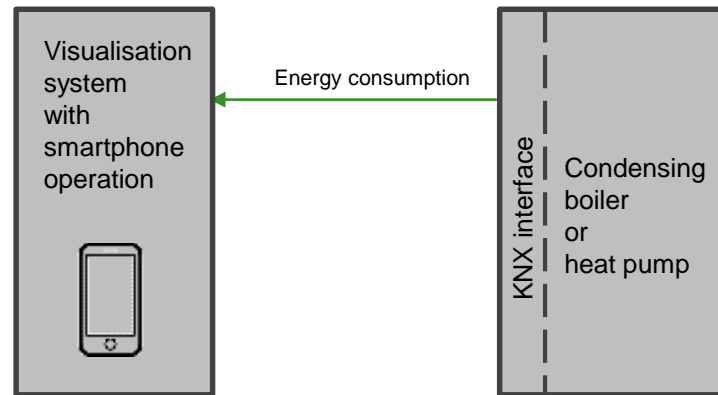

Energy consumption: real energy (kWh)
4 byte / DPT 13.013



Case study 3 - Visualisation of HVAC-related parameters



KNX solution for case B Displaying operating states on the smartphone

Almost all the operating states can be queried via the KNX interface and displayed in the visualisation including: heating, cooling, active heating program, day / night mode, HV pumps, DHW heating, active electric night heating, service, etc.

When there are system errors, error messages are automatically sent to the visualisation via the KNX, either as individual fault messages or as group messages (“Faults of heat generator”).

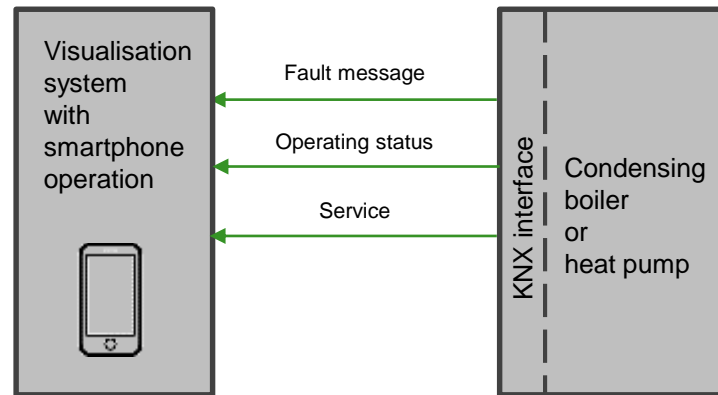

Fault message,
Operating status:

1 bit / DPT 1.00x
1 byte / DPT 6.020
1 byte / DPT 20.xxx

Case study 3 - Visualisation of HVAC-related parameters



KNX solution for case C

Note about the next service interval

The note about the next service date can be carried out in different ways:

1. The heat / cooling generator determines the necessity of a service appointment itself and sends a request in the form of a yes / no telegram to the visualisation system.
2. The running times of the HV and storage pumps, compressors, electric heaters etc. are sent as absolute values to the visualisation, compared with the specified maintenance intervals and the next service period is calculated.

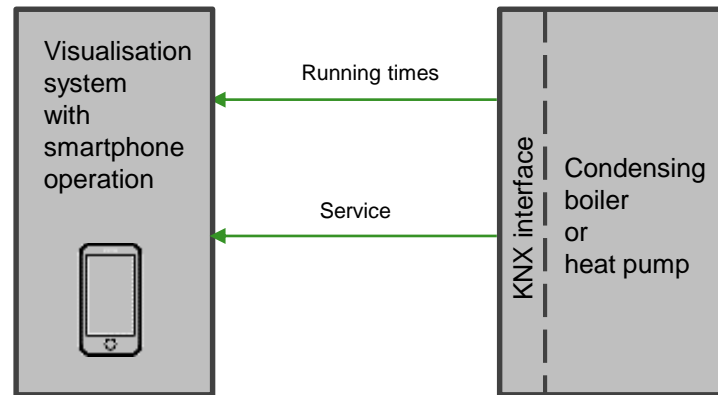

Running times:
TimePeriodHrs
2 byte / DPT 7.007

Case study 4 - Optimisation for optional power consumption of heat pumps



Heat pumps belong to the most energy-intensive devices in the building. There is therefore a high added value for the customer to integrate these systems in the energy management so that they can be operated cost-effectively.

Case A: The service water is heated if the electricity is reasonable.

Case B: The heating or cooling is carried out within a tolerance range defined by the customer if the electricity is reasonable.

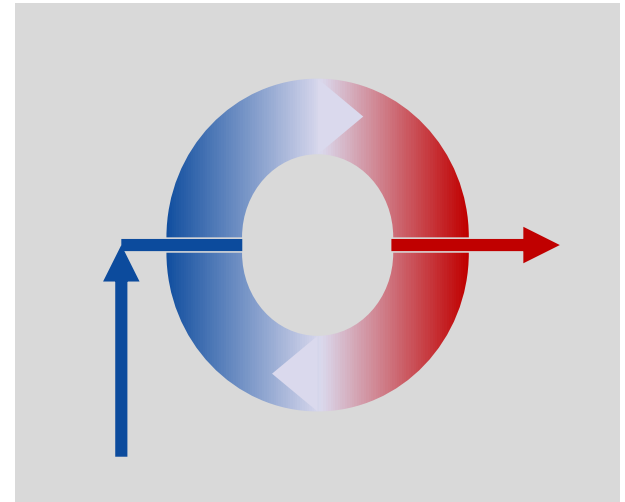

Case study 4 - Optimisation for optional power consumption of heat pumps



KNX solution for cases A/B
Heat pumps can represent optional processes (e.g. heating or cooling) on the communication interface, so that these processes can be started by an energy management system under favourable conditions.

Use of SG ready functions for heat pumps with Smart Grid capability

- Operating status 1 is backward compatible to utility lock, incorporates a maximum lockout period of two hours
- Operating status 2 the energy-efficient normal operation with pro-rata filling of thermal store for the maximum lockout period of two hours
- Operating status 3 is the controller mode for heating rooms and water
- Operating status 4 is a definitive start-up command

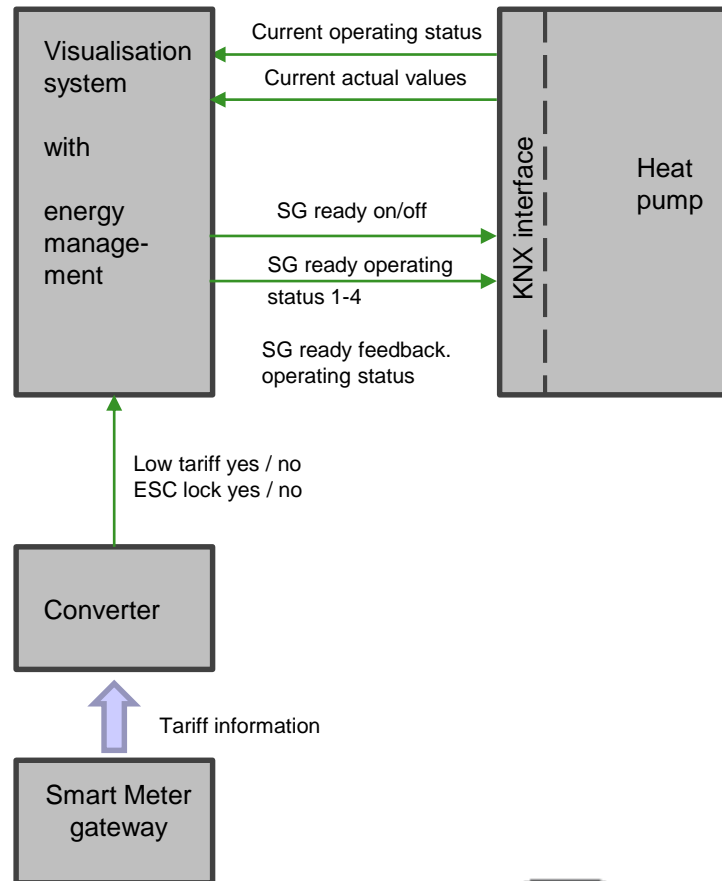

SG ready operating status:
1 bit / DPT 1.0xx

SG ready mode
1 byte / DPT 20.xxx



<http://www.waermepumpe.de/waermepumpe/sg-ready/>

Case study 4 - Optimisation for optional power consumption of heat pumps



KNX solution for cases A/B
Heat pumps can represent optional processes (e.g. heating or cooling) on the communication interface, so that these processes can be started by an energy management system under favourable conditions.

Control with a conventional heat pump via operating modes and setpoint values.

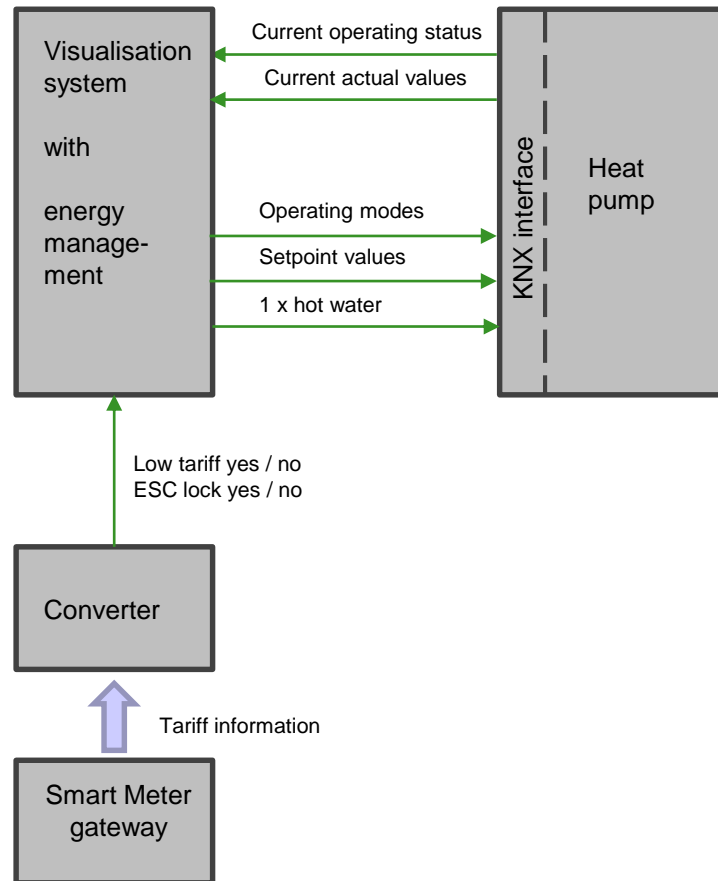

Case study 5 - Heat pump power consumption forecast



Heat pumps belong to the most energy-intensive devices in the building. There is therefore a high added value for the customer to integrate these systems in the energy management so that they can be operated cost-effectively.

Case A: Further energy-intensive processes which exceed the domestic current of the PV system are prevented from starting during the heating cycles.

Case B: The user can be shown when heating cycles take place and at what price.

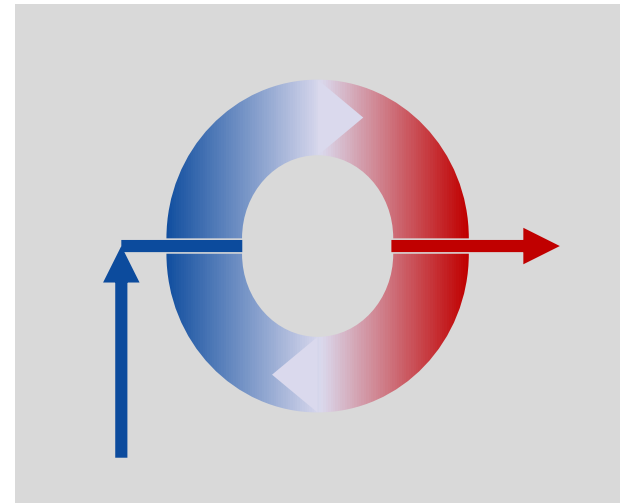

Case study 5 - Heat pump power consumption forecast



KNX solution for cases A/B
 Heat pumps can represent optional processes (e.g. heating or cooling) on the communication interface, so that these processes can be started by an energy management system under favourable conditions

Operating states and forecast data can be communicated by heat controllers to a visualisation program via the KNX and displayed as values, diagrams or graphics.

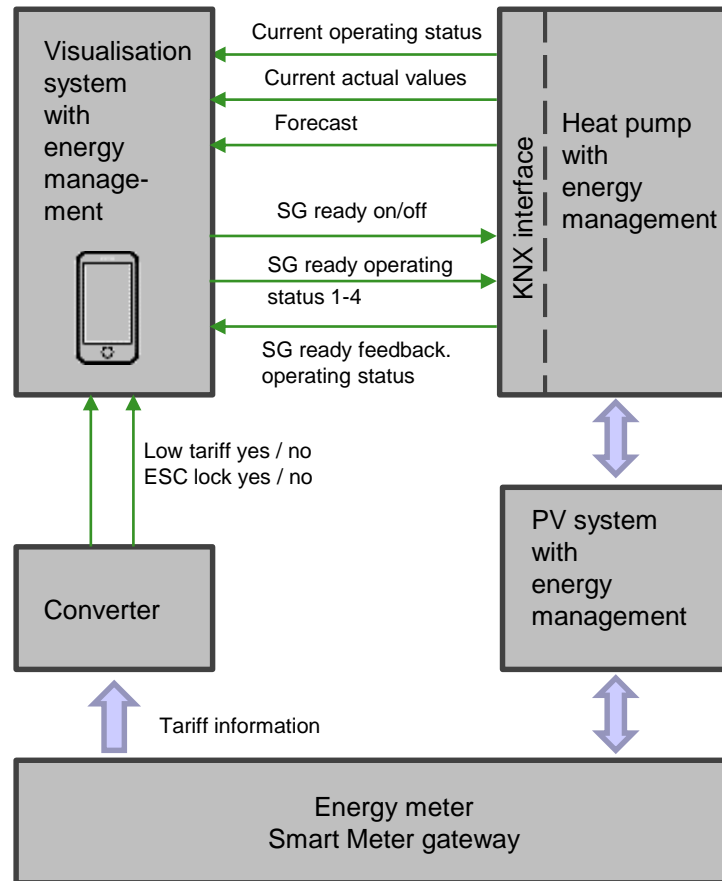

The heat pump determines the thermal energy demand of the building and communicates the power requirement to the PV system.

The PV system plans the operating time of the devices under consideration of a yield and consumption forecast so that the power consumption makes an optimum contribution to the domestic consumption.

The heat pump converts this proposal dependent on the operating state and thus increases the domestic consumption. Electrical energy is converted into thermal energy cost-effectively and stored temporarily in the house.

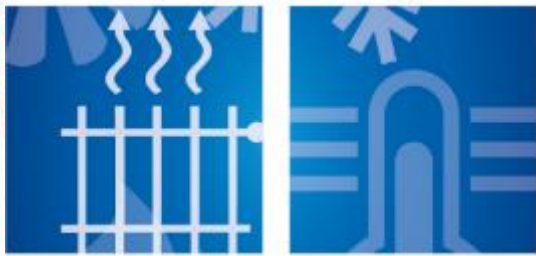

**Heating, cooling, ventilation
with KNX**

Training

www.knx.org

Start@KNX

3 easy ways to become an expert in KNX

On-site Training

Online Training

Literature

- **KNX Basic Course**
Getting familiar with KNX and become a certified KNX Partner
- **KNX Advance Course**
Extend your KNX Knowledge
- **KNX Tutor Course**
Become a KNX Trainer

Start@KNX



3 easy ways to become an expert in KNX

On-site Training

Online Training

Literature

- **KNX Brochures**
Brochures about all aspects of KNX
- **KNX Books**
Introduction books as well as official training course documentations
- **3rd Party literature**
Various languages about further aspects of KNX by independent authors

Start@KNX

3 easy ways to become an expert in KNX

On-site Training

- **KNX Basic Course**
Getting familiar with KNX and become a certified KNX Partner
- **KNX Advance Course**
Extend your KNX Knowledge
- **KNX Tutor Course**
Become a KNX Trainer

Online Training

- **ETS eCampus**
Free online training for beginners
- **KNX Webinars**
Interactive KNX Presentations
- **Online KNX Basic Course**
Preparation for certified Courses

Literature

- **KNX Brochures**
Brochures about all aspects of KNX
- **KNX Books**
Introduction books as well as official training course documentations
- **3rd Party literature**
Various languages about further aspects of KNX by independent authors

KNX HVAC on-site training

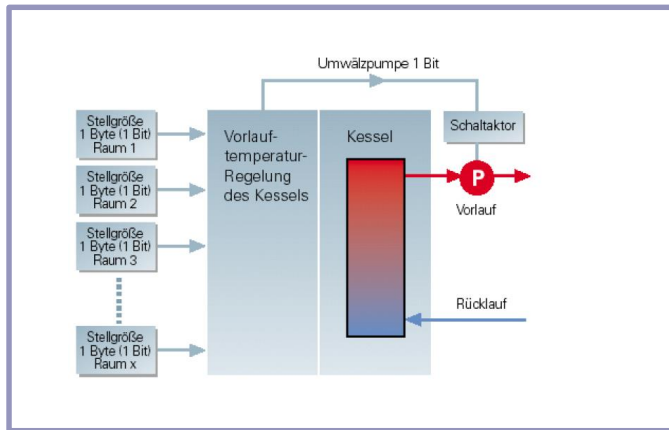

"Climate control with KNX" as part of the KNX Advanced course

A large part of the KNX Advanced course already deals with HVAC topics:

- Types and function of heating components
- Integration of the heating system into building management system
- Single-room control and KNX gateways
- As well as: fan coil, ventilation, integration of air conditioning systems, indoor and outdoor sensors

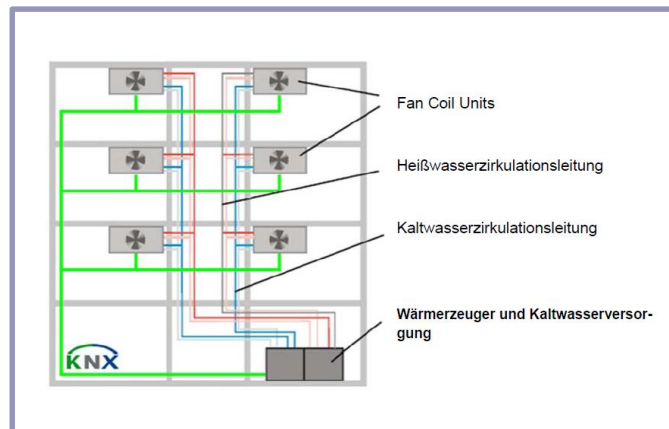

KNX HVAC on-site training

New for
May!



New HVAC training



- **“Heating, cooling and ventilation with KNX”** as a two-day course
- **Target group:**
Primarily specialists in electrotechnology with experience in electrical installation with experience and knowledge of installation in the HVAC sector
- **Your benefits:**
 - You will receive solid, basic knowledge about HVAC applications in home and building technology using KNX.
 - Important HVAC terms, contexts and typical HVAC components are clearly explained using practical examples.
 - You will be technically qualified to communicate with HVAC manufacturers and specialists.

KNX HVAC on-site training

New for
May!



New HVAC training

- **With additional topics**



- **Basic know-how:**
Temperature, heat, thermal energy, thermal capacity, humidity, dew point, formation of condensation and its consequences, ...
- **Heat distribution systems:**
Thermal comfort, temperature profiles, heat distribution systems, heat pumps, heating surfaces, heating fittings, heat meters
- **Heat generators:**
Operation of mini CHP plants and heat pumps, solar heat, conventional heat generators, domestic water heating
- **In-depth understanding of control and regulation:**
Continuous-action and switching controllers, practical setting of the control parameters not only for individual room thermostats

KNX HVAC on-site training

New for May!



New HVAC training

- **With additional topics**

- **Heating control:**
Regulation of flow temperature and room temperature, significance of hydraulic balancing
- **Domestic water heating:**
Storage / flow-through principle, avoidance of legionella, heat exchangers, ...
- **Increase in energy efficiency with KNX:**
with KNX through individual room temperature control dependent on room usage, influence of flow temperature, influence of domestic water temperature, influence of pressure of the circulating pump, ...
- **KNX interfaces / gateways** for heat generators
- ... and more practical exercises!



KNX HVAC on-site training

New for May!



New HVAC training



- **Certification**

After passing the final exam, you will receive the official KNX certificate.

- **Dates**

The first course will be held on 3rd and 4th May 2017 at BFE in Oldenburg. Go to www.bfe.de for information and to register.

Further training courses to follow.

HVAC training in KNX training centres

Where can I find information on KNX training?

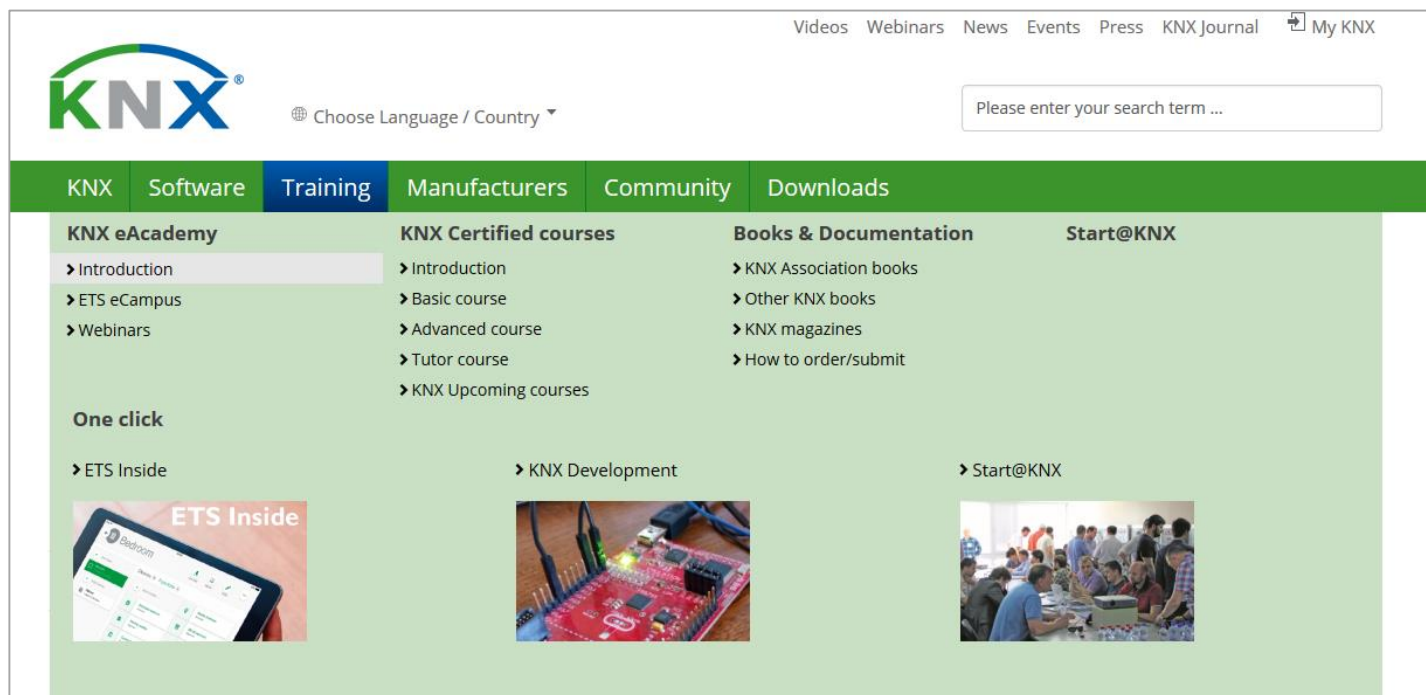



The screenshot shows the KNX website interface. At the top right, there are links for Videos, Webinars, News, Events, Press, KNX Journal, and My KNX. The main navigation bar includes KNX, Software, Training (highlighted), Manufacturers, Community, and Downloads. Below the navigation bar, there are four main sections: KNX eAcademy, KNX Certified courses, Books & Documentation, and Start@KNX. Each section contains a list of links and a corresponding image.

- KNX eAcademy**
 - Introduction
 - ETS eCampus
 - Webinars

One click

 - ETS Inside
- KNX Certified courses**
 - Introduction
 - Basic course
 - Advanced course
 - Tutor course
 - KNX Upcoming courses

KNX Development

- Books & Documentation**
 - KNX Association books
 - Other KNX books
 - KNX magazines
 - How to order/submit
- Start@KNX**
 - Start@KNX

<http://start.knx.org/>

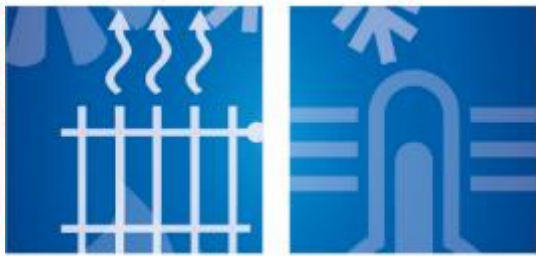

**Heating, cooling, ventilation
with KNX**

HVAC website

www.knx.org

HVAC website



Networking of the room automation functions

In addition to classic lighting and sun protection control, applications for heating, ventilation and air conditioning (HVAC) in particular form an essential part of modern room and building automation. As a worldwide standard for home and building system technology, KNX also integrates further applications.

Considering that home and building automation accounts for 40% of the total energy consumption, energy efficiency is paramount as well as an increase in comfort. The energy efficiency of buildings as well as the influence of building automation is described in the European standard EN 15232. The methods described there evaluate the influence of the building automation and the technical building management on the energy consumption. The standard classifies building automation and control systems into four energy efficiency classes A to D. While efficiency class C only requires the minimum legal standard without energy saving automation, the networking of energy efficient room automation functions is necessary for all applications and demand-oriented control to achieve class A.

KNX offers not only the technical requirement for the integration and communication of the different applications and products but has already shown in a variety of studies and projects that savings of 50% to 60% can be achieved through individual room control and ventilation control alone.

KNX Flyers

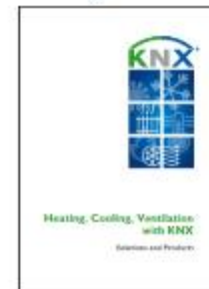

Available in 2 languages

[Download \(1,6 MB\)](#)

<http://hvac.knx.org>



**Thank you very much
for your attention**

**For any questions, contact
info@knx.org – www.knx.org**

www.knx.org



KNX
The worldwide STANDARD
for
home and building control

www.knx.org

KNX Association International

More info needed?



Visit the KNX website

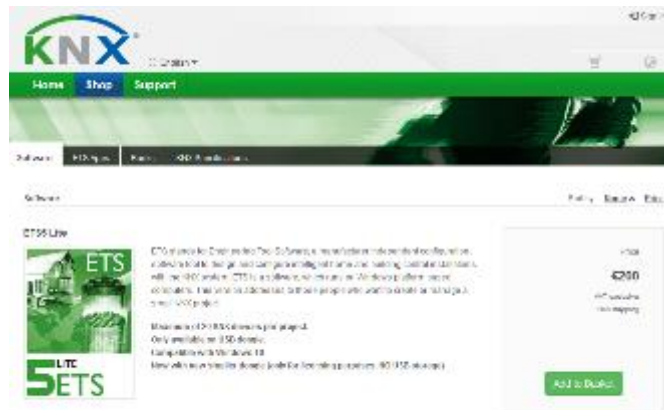

Order our tools in MyKNX



Brochures and presentation in our download section



Buy our eBooks on Amazon

<http://www.knx.org> | <http://my.knx.org>

Start@KNX



Enrol in our KNX webinars



Discover ETS5 via the eCampus



Follow a certified KNX course



Join an online training program

More info: <http://start.knx.org>

Join the worldwide KNX community



Join us!



Follow us on social media

WWW.KNX.ORG





**Thank you very much
for your attention**

**For any questions, contact
info@knx.org – www.knx.org**

www.knx.org