



Smart home and building solutions.
Global. Secure. Connected.

KNX SYSTEM PRINCIPLES



CONTENT

Introduction	4
---------------------	----------

Conventional system	5
Switch types	5
Building functions	6
Conclusions	7
What is the alternative?	7

Bus system	8
Components	8
Working	8
Tool	9

Bus system advantages	12
Flexibility	12
Power separated from operation	12
Optimized cabling	12
Individual devices can have multiple functions	13

KNX specific advantages	14
Product certification	14
Saving energy	14
Making combinations	14
Decentralized bus system	15

INTRODUCTION

During the last 50 years, science and technology have developed in a swift manner. E.g. phones, with higher capacities than the computers used for the landing on the moon, are now considered as rather common. This technological evolution also propagated into the electrical installations of houses and buildings, dealing with all sorts of applications, such as lighting, shutter control, HVAC, as well as security and energy management.

Whilst conventional switching is still commonly used for the residential sector, the requirements and hence the complexity of those conventional installations escalate rapidly. Such further extensions require additional devices, like relays and timers and most of all additional wiring. Needless to say that commercial buildings, such as hotels and offices face even higher requirements and complexity, in order to accommodate the needs for each user. The answer, in order to realise all these automated functions without losing valuable time and invest in additional wiring, is building control with KNX®
- The worldwide STANDARD for home and building control.

Building control with KNX found its way into everyone's life in the year 1990, at which actuators and sensors, each provided with a microchip, are connected via a bus cable. The success of this new technology was determined by the possibility to control everything, which runs on electricity in a building as well as its flexible and easy configuration. Reprogramming instead of conventional re-wiring opened a new dimension of managing electrical installations of houses and buildings, which allows to add, adjust, modify, change, repair, any room function with - in a manner of speaking - just a few mouse clicks.

Even in times of Smart Grids, where optimizing the use of renewable energy has a key role, conventional installations play and will always play an important role for houses and buildings. This publication will bring you closer to how KNX in combination with this conventional technology, allows every owner to make an investment in sustainability and the future.

Without any doubt, this publication will open your eyes to the fantastic world of building automation with KNX and will specifically teach you about the flexibility of building automation with KNX.

CONVENTIONAL SYSTEM

In order to explain the KNX system principles we should go way back in time: before the 80's. Back then, most electrical installations in houses mainly controlled lighting, in some larger building also blinds were controlled with conventional electrical technology.

Switch types

Let's have a look first at the three different conventional switch types in order to explain the working of conventional systems.

Simple switch

Simple switches have:

two junctions: 'a' and 'b'

two positions:

- closed: junction 'a' is connected with junction 'b'
- open: junction 'a' is not connected with junction 'b'

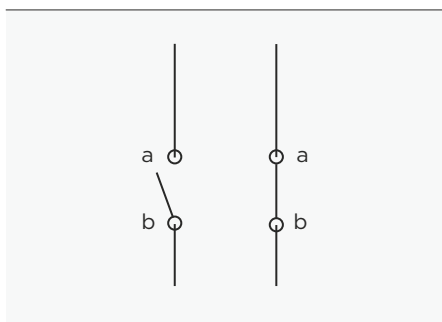

Toggle switch

Toggle switches have:

three junctions: 'a', 'b' and 'c'

two positions:

- left: junction 'a' is connected with junction 'b'
- right: junction 'a' is connected with junction 'c'

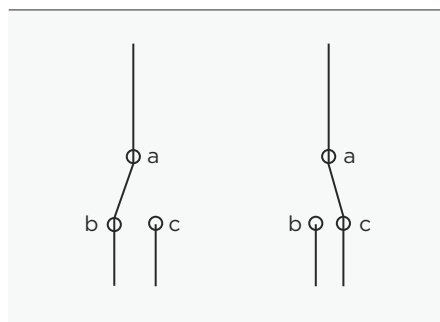

Cross switch

Cross switches have:

four junctions: 'a', 'b', 'c' and 'd'

two positions:

- parallel: junction 'a' is connected with junction 'c' and junction 'b' with junction 'd' (left Figure)
- crossed: junction 'a' is connected with junction 'd' and junction 'b' with junction 'c' (right Figure)

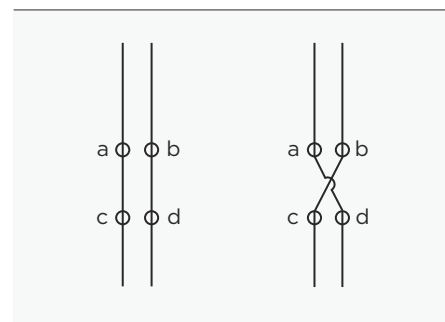

Building functions

The actual conventional (building) functions are based on conventional switches. This clause gives an overview of such conventional functions, from most basic till most complex.

Single switch function

The most basic function type of a conventional electrical system is the single switch function; this function type can switch an electrical consumer from one operating point and is based on a conventional simple switch.

The Figure illustrates the working of a single switch function. The symbols 'L' and 'N' represent the conventional mains wires, 'S1' represents a conventional simple switch and 'E1' the electrical consumer, in this case a lamp.

The Table explains the correlation between the switch position and the status of the lamp:

- **IF S1** is closed **THEN** the electrical circuit is closed, an electrical current will flow and hence the lamp will be lit
- opening S1 again will interrupt the electrical current and the lamp will no longer be lit

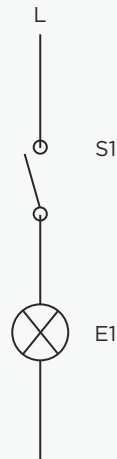

S1	E1
Open	Off
Closed	On

Double switch function

Suppose that two independent operating points are required for lamp E1. Adding a second simple switch will not help here, because they cannot be operated independently: they both need to be closed in order to switch on the lamp (in any other combination the lamp would be switched off).

The solution is to use two conventional toggle switches. The Figure illustrates the working of a double switch function. The symbols 'L' and 'N' represent the conventional mains wires, 'T1' and 'T2' represent two conventional toggle switches and 'E1' an electrical consumer, in this case a lamp.

The Table explains the correlation between the switch positions and the status of the lamp:

- **IF** both T1 and T2 are put in the same position (either both 'left' or both 'right') **THEN** the electrical circuit is closed, an electrical current will flow and hence the lamp will be lit
- putting T1 or T2 in opposite positions will interrupt the electrical current and the lamp will no longer be lit

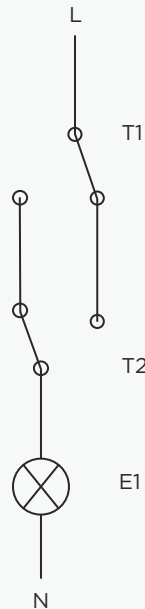

T1	T2	E1
Left	Right	Off
Left	Left	On
Right	Right	On
Right	Left	Off

Multiple switch function

Suppose that x independent operating points are required for lamp E1. The solution is to add $x-2$ cross switches between two toggle switches.

E. g. if $x=7$, then 5 cross switches need to be installed between two toggle switches (and the lamp itself of course).

The Figure illustrates the working of a multiple switch function. The symbols 'L' and 'N' represent the conventional mains wires, 'T1' and 'T2' represent two conventional toggle switches, 'C1...Cn' represents n conventional cross switches and 'E1' an electrical consumer, in this case a lamp.

A table explaining the correlation between the switch positions and the status of the lamp can, depending on the number cross switches installed between the two toggle switches, become quite big.

Such table can however be summarized as follows – the lamp will be lit:

- **IF** both T1 and T2 are put in the same position (either both left or both right) **AND** given an even number of cross switches in crossed position
- **IF** T1 and T2 are put in opposite positions **AND** given an odd number of cross switches in crossed position

Any change will switch off the lamp again.

The Table explains the correlation between the switch positions and the status of the lamp for a multiple switch function where only one crossed switch C1 is used (3 independent operating points) and is a good illustration for the complexity of multiple switch functions.

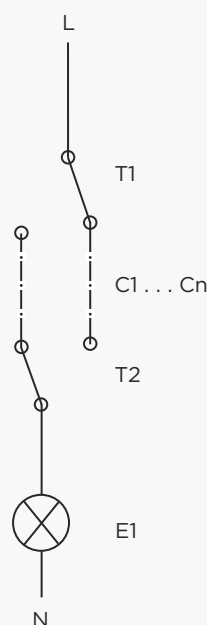

C1 . . . Cn

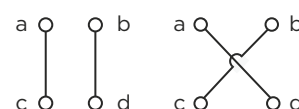

T1	C1	T2	E1
Left		Left	On
Left		Right	Off
Left	X	Left	Off
Left	X	Right	On
Right		Left	Off
Right		Right	On
Right	X	Left	On
Right	X	Right	Off

Conclusions

A first conclusion is that the functionality within a conventional system is hardwired, i. e. the combination of the installed switch types and especially how these switches are wired together, defines the functionality of an electrical installation.

A consequence of this concept is that even the number of wires per control point needs to be planned, i. e. toggle switches require three wires and cross switches require four wires.

The above is about the direct conclusions, but especially for larger buildings the indirect conclusions are actually even more important, their conventional electrical systems:

- Have a complex, cumbersome, time consuming and thus expensive cabling.
- Have an unfavorable functionality/cable ratio, i. e. they relatively require large cable quantities for little functionality (lighting).
- Are not flexible, adding e. g. one extra operating point (switch) is very cumbersome.
- Have no separation between power and operation, i. e. conventional switches control electrical consumers directly.

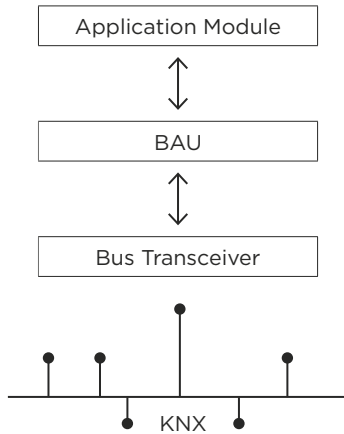

Figure 1. bus device

BUS SYSTEM

This clause explains the working of a bus system step by step. Each such step explains one aspect of a bus system in general and at the same time a KNX system principle specifically, where applicable at least.

Components

Devices

A bus system is to be seen as a collection of bus devices. As just explained above, a KNX (bus) device consists out of a microcontroller, a bus transceiver and an application module. KNX devices can be divided into two groups: active devices and passive devices. Passive devices do not have ICT onboard, they 'only' have a supporting or indirect role; i. e. they do not communicate with other devices but are absolutely required in order to set up bus systems properly. Examples of passive devices are power supplies. Please note, that e. g. also power supplies could be extended with ICT, but this is not very common. The other group, i. e. the active devices can be divided into the following device categories:

Interfaces

their role is to connect a PC with a bus system

Couplers

their role is to optimize the communication efficiency of bus systems

Sensors

they contribute information to bus systems, e. g. 'requested living room temperature = 22.5°C'

Actuators

they link (conventional) electrical consumers with bus systems, e. g. lamp connected to a lighting actuator output

About sensors and actuators

Application modules of sensors typically convert analogue signals or user actions, like:

- temperature
 - push button rocker operations
 - rain detection
 - wind speed
 - touch screen manipulations
 - etc.
-

Application modules of actuators are typically connected with:

- an electrical consumer (e.g. a light ballast via relays)
 - HVAC systems via valves
 - etc.
-

Application modules are electronically connected to microcontrollers.

What is the alternative?

The best alternative is a bus system

The best alternative is called ICT, which is the abbreviation for Information and Communication Technology. Or better said the alternative to be more precise is a concept based on ICT. The three key aspects of this concept are:

- To replace ALL conventional switches (regardless of the type) by push buttons being able to communicate or to connect conventional push buttons / switches to interfaces being able to communicate.
- To add to ALL electrical consumers (regardless of the type) an interface being able to communicate or to control electrical consumers indirectly by switching devices being able to communicate.
- To link all devices being able to communicate via a dedicated extra low voltage cable.
- This concept is called a 'Bus System' and the cable linking the microcontrollers is called the 'Bus Cable' or short the 'Bus'.

Bus system = collection of bus devices

The electronics for the communication is equipped with a microcontroller which has on one hand an interface to the appliance, e.g. operating elements, and on the other hand to the bus, see Figure 1:

- The composed electronics implementing the interface to bus called 'bus transceiver'.
- The composed electronics implementing the appliance called 'application module'.
- A device being connected to the bus and able to communicate with other devices is called a bus device.

Conclusion – A (bus) device consists out of:

- A microcontroller (μC)
- A bus transceiver
- An application module

The combination of microcontroller and bus transceiver is called bus access unit (BAU).

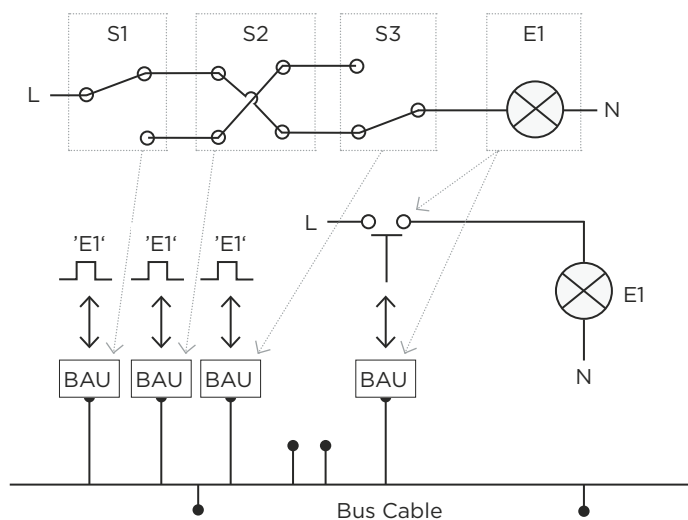

Figure 2. Converting a conventional system into a bus system

How to convert a conventional system into a bus system

In this example, see Figure 2: a conventional triple switch function is replaced by three sensors and one actuator:

- Each switch is replaced by a push button + bus access unit. All by all these are three individual devices that belong to the same network.
- The electrical consumer is replaced by a relay + bus access unit (+ the actual lamp of course). This is again an extra individual device that also belongs to the same network.

Working

Divided functionality

Figure 3 illustrates the divided functionality aspect of bus systems:

The three sensors are located on the left hand side. Each of these sensors converts rocker manipulations into electronic pulses. Each such electronic pulse represents an E1 user operation. The actuator is located on the right hand side and controls the relay connected to E1.

Exchanging messages in order to link devices

The way sensors and actuators communicate in bus systems is by exchanging messages.

Example, see the above Figure 3: divided functionality of a bus system, suppose that the user manipulates one of the sensor rockers, this will induce an electronic pulse which will be processed by the microcontroller. The result is that the sensor will broadcast a message on the bus, here in this case the message is: 'someone wants to operate E1'.

In KNX such message is called a telegram. A KNX sensor will in the above case send out a telegram with amongst others the following data:

- The 'FunctionID': here the FunctionID = E1
- The 'FunctionValue': here FunctionValue = 0 (switch off) or FunctionValue = 1 (switch on)

All other sensors and actuators of the bus will receive this telegram and process it:

- Sensors will simply ignore this telegram
- ONLY the actuators with the SAME FunctionID = E1 will react accordingly: i.e. switch on/off E1

Conclusion: in KNX, sensors and actuators are connected together by exchanging telegrams, or in other words:

- In conventional systems operating elements and electrical consumers are directly and physically linked via wires
- In bus systems operating elements and electrical consumers are indirectly and virtually linked via messages exchanged between microcontrollers

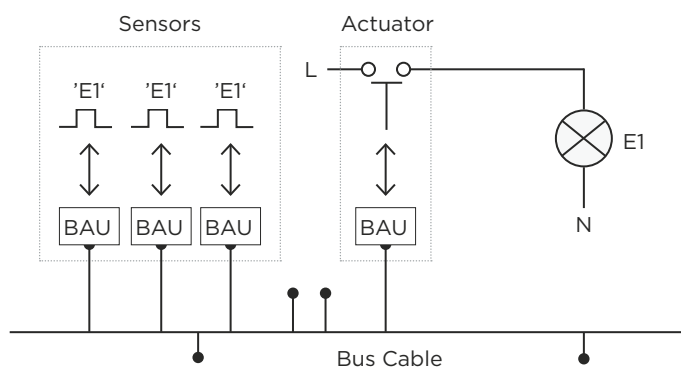

Figure 3. Divided functionality of a bus system

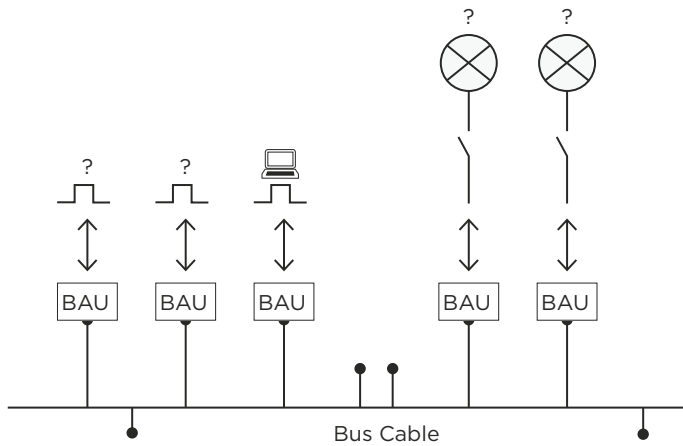

Figure 4. Required = Interface + Computer + Software tool

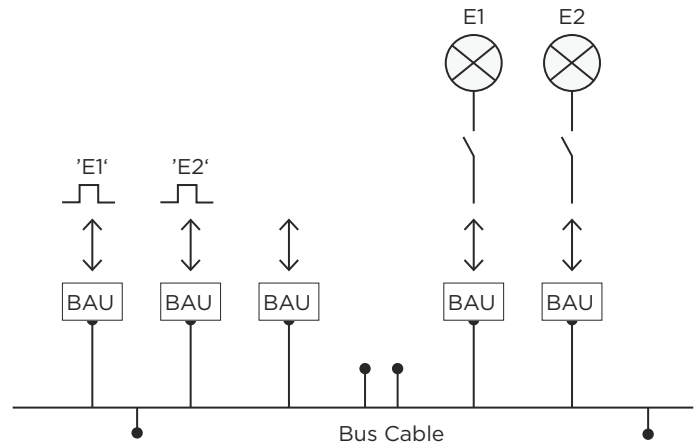

Figure 5. Working with ETS is convenient

Tool

Bus systems = easy modifications

Making modifications to a bus system generally can be split into two separate tasks:

- Physically adding and/or removing and/or replacing devices
- Modifying device functionality

The first part has already been addressed before, i. e. making modifications to the electrical part of a bus system is easy and moreover safe because of the extra low voltage wires. Also for actuators this is the case; they are typically installed in a cabinet, i. e. safe and well hidden from any user of the installation. Please also note that possible modifications to the building structure (i. e. demolition work) are in most cases only required for sensors and thus for extra low voltage cabling, because actuators usually are installed in cabinets.

Equipment required in order to modify bus systems

See Figure 4, the equipment required in order to modify bus systems is:

- A PC with a software tool onboard
- An interface connecting the bus to a PC

The software tool for KNX is called ETS, which is the abbreviation for Engineering Tool Software. Device functionality is stored into the memory of each device individually. In order to change the functionality of a device, its memory image needs to be modified, and exactly this is the role of ETS: changing device memory.

Conclusion: modifying a KNX installation means reprogramming with ETS. Modifying a conventional system means rewiring, which again is a very cumbersome task.

Working with ETS is convenient

See Figure 5, typical ETS tasks are:

Fine tuning functionality:

e.g. set up a stairway function for the E2 actuator. Such stairway function will switch E2 automatically off after a while, this is convenient for residents of the building and it saves energy at the same time.

Modifying functionality:

e.g. make sure that a specific sensor (operating point) no longer serves E1 but E2 instead.

Adding functionality:

e.g. an actuator already serving E1 shall also serve E2 (given there is at least still one output channel available).

Extending existing functionality:

e.g. add an extra sensor (operating point) for E2.

A virtual link in KNX = Group Address

The following screenshots illustrate the true convenience of working with ETS. But first this:

- Remember: in bus systems sensors and actuators are virtually linked by exchanging messages.
- In KNX such message is called a Telegram.
- Each virtual link can be defined as a function identifier representing one electrical consumer of the installation, like e.g. 'E1'.
- In KNX such virtual link is called a **Group Address**.

Group Addresses ▾		
+ Add Middle Groups ✖ Delete ⬇ Download ⓘ Info ⌛ Reset ⚡ Unload ▾		
Group Addresses ▾	Object	Device *
Dynamic Folders	0: - channel 1 - on/off	1.1.10 push button 1-fold
0 New main group	0: - channel 1	1.1.100 binary output 1-fold
0/0 New middle group		
0/0/1 E1		

Initial situation, one sensor and one actuator in E1

'E1' is the name of the Group Address = 0/0/1, this Group Address represents all devices that are involved in this function.

In the initial situation only two devices are present in the building function E1:

- One sensor, being device '1.1.10'
- One actuator, being device '1.1.100'

Group Addresses ▾		
+ Add Middle Groups ✖ Delete ⬇ Download ⓘ Info ⌛ Reset ⚡ Unload ▾		
Group Addresses ▾	Object	Device *
Dynamic Folders	0: - channel 1 - on/off	1.1.10 push button 1-fold
0 New main group	0: - channel 1 - on/off	1.1.11 push button 1-fold
0/0 New middle group	0: - channel 1 - on/off	1.1.12 push button 1-fold
0/0/1 E1	0: - channel 1 - on/off	1.1.13 push button 1-fold
	0: - channel 1 - on/off	1.1.14 push button 1-fold
	0: - channel 1 - on/off	1.1.15 push button 1-fold
	0: - channel 1 - on/off	1.1.16 push button 1-fold
	0: - channel 1 - on/off	1.1.17 push button 1-fold
	0: - channel 1 - on/off	1.1.18 push button 1-fold
	0: - channel 1 - on/off	1.1.19 push button 1-fold
	0: - channel 1	1.1.100 binary output 1-fold

Add more sensors for E1

The sensors added are the devices '1.1.11' till '1.1.19'.

Group Addresses ▾		
+ Add Main Groups ✖ Delete ⬇ Download ⓘ Info ⌛ Reset ⚡ Unload ▾		
Group Addresses ▾	Object	Device *
Dynamic Folders	0: - channel 1 - on/off	1.1.10 push button 1-fold
0 New main group	0: - channel 1 - on/off	1.1.11 push button 1-fold
0/0 New middle group	0: - channel 1 - on/off	1.1.12 push button 1-fold
0/0/1 E1	0: - channel 1 - on/off	1.1.13 push button 1-fold
	0: - channel 1 - on/off	1.1.14 push button 1-fold
	0: - channel 1 - on/off	1.1.15 push button 1-fold
	0: - channel 1 - on/off	1.1.16 push button 1-fold
	0: - channel 1 - on/off	1.1.17 push button 1-fold
	0: - channel 1 - on/off	1.1.18 push button 1-fold
	0: - channel 1 - on/off	1.1.19 push button 1-fold
	0: - channel 1	1.1.100 binary output 1-fold
	0: - channel 1	1.1.101 binary output 1-fold
	0: - channel 1	1.1.102 binary output 1-fold
	0: - channel 1	1.1.103 binary output 1-fold

Add more actuators for E1

The sensors added are the devices '1.1.101' till '1.1.103'.

And again: imagine doing the same with a conventional system, this reflection makes it really easy to understand the enormous potential of KNX installations.

BUS SYSTEM ADVANTAGES

Flexibility

The flexibility aspect is indeed the most important advantage of the bus concept. A comparison with a conventional multiple switch function helps understanding this.

See Figure 6 - e.g. $n = 2$. Suppose that one extra operating point for E1 needs to be added, i.e. one extra crossed switch (C3). As such this might look like a simple task but in practice it really is not: remember that conventional systems have hard-wired functionality: it is absolutely necessary to find out which wire goes where exactly, i.e. four low voltage wires in total need to be connected. With a bus system, the same task is much easier: just connect another sensor and make sure it is linked to the same FunctionID, see Figure 3: divided functionality of a bus system.

The only requirement in order to add a sensor (or any bus device for that matter) is to make sure that it is properly connected to the bus, in case of KNX TP: just two extra low voltage wires need to be connected. Now imagine that the same task needs to be done for five, ten or even more operating points for E1.

With a conventional system this will take hours or maybe even days, the time spent on the same task for a bus system is simply not comparable anymore, not to say neglectable. Please note that such action with a conventional system is not a very common practise, it is only to explain a principle.

Bottom line: with bus systems it is far more easier to:

- first of all create complex functions
- to modify and/or to extend them.

Power separated from operation

This is a direct consequence of the divided functionality aspect:

- Sensors are connected to the bus via extra low voltage (i.e. KNX TP = ~29 V) wires, the application modules (e.g. rocker) are connected to sensors via even lower voltages (3.3V or 5V).
- Actuators are also connected to the bus via extra low voltage wires, the application modules (e.g. relay) operate in most cases low voltage consumers. But actuators are typically installed in separate cabinets, i.e. safe and well hidden from any user of the installation.

As such this might not look like a real advantage because it does not really change the functionality, the real advantage is the safety aspect: if anything would go wrong then in worst case the user is only exposed to extra low voltages, which in no way can cause any harm to human beings.

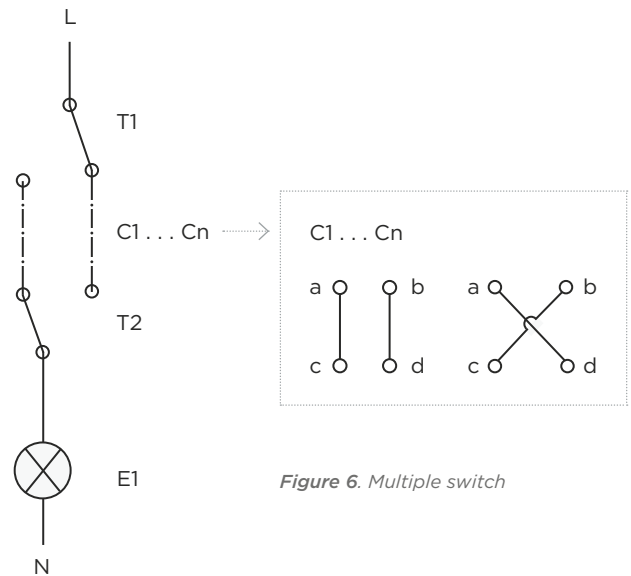

Figure 6. Multiple switch

Optimized cabling

Cheaper cabling

This is a direct consequence of the flexibility aspect. Compared with conventional system, the following tasks can be done in no time:

- Adding devices
- Removing devices
- Replacing devices

Conclusion: easy cabling = faster cabling. Moreover: extra low voltage wires are thinner and are therefore easier to handle and install.

Higher functionality/cable ratio

The question here is: how much cable and hence copper is required to set up the composed functionality of an entire electrical installation? Setting up e.g. a switch function with 20 controlling points in a conventional system takes tremendously more cable and hence more copper than for the same function realized with a bus system. This comparison becomes even more impressive when looking at the entire installation, and certainly for bigger installations, like e.g. an office building with x floors. Moreover, until now only one application type, namely lighting, has been addressed: when also other application types, like blinds, HVAC, security, white goods, etc. need to be considered then a comparison between bus systems and conventional systems simply is no longer applicable: setting additional application types (like blinds) based on conventional system makes the job only more complicated, also it will again only take more cable. As such this might actually even be the most important argument for bus systems: in order to add other building functions and/or building function types no parallel cabling is required, simple use and/or extend the bus cable that is already in use.

Individual devices can have multiple functions

Two separate actuators for E1 and E2

Actuators: serve more than one electrical consumer

- One sensor sends telegrams for E1 on the bus
- Another sensor does the same for E2
- One actuator serves E1
- Another actuator serves E2

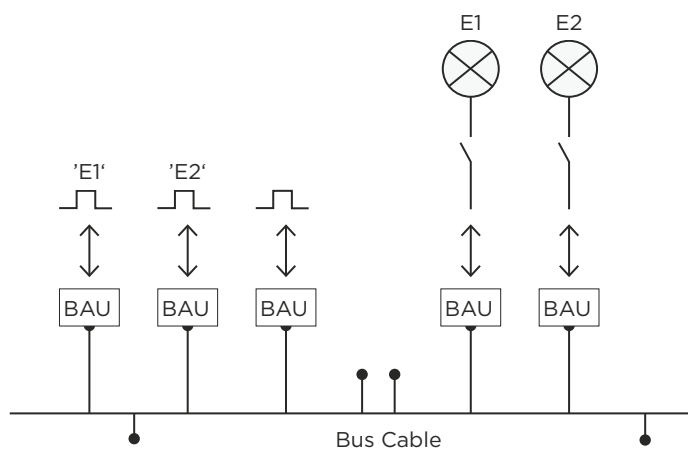

One actuator serving both E1 and E2

In this Figure the situation is a bit different: now there is only one actuator serving both E1 and E2.

The advantages are:

- less bus cable (certainly for installation with thousands of building functions/bus devices)
- reduced number of devices

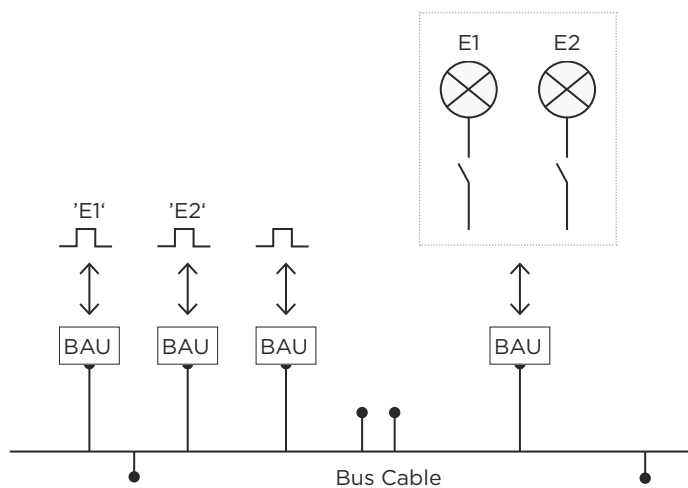

Sensor serving both E1 and E4

Sensors: combine functions and function types

- E1 and E2 represent two light points
- E3 and E4 represent two electrical motors (e.g. E3 = blinds, E4 = garage gate)
- The sensor on the left hand side can send telegrams both for E1 and E4
- One actuator serves both E1 and E2
- Another actuator serves both E3 and E4

Not only does this example illustrate that sensors can combine functions, it also points out that sensors can combine function types, here in this case:

- One rocker serving a lamp
- Another rocker serving e.g. blinds (electrical motor)

Moreover, also actuators can combine function types.

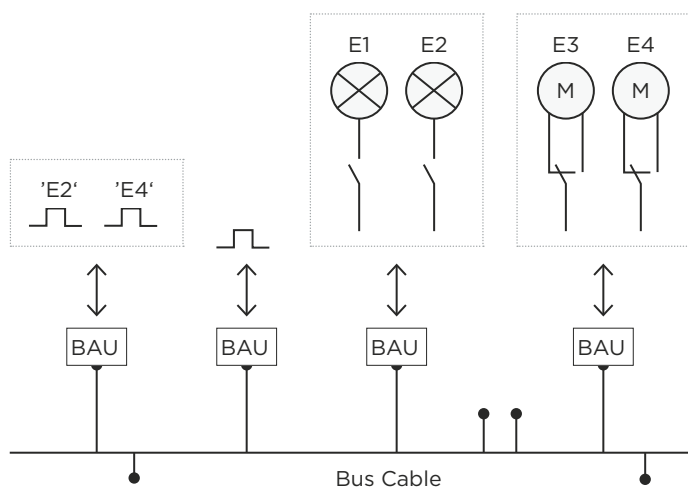

KNX SPECIFIC ADVANTAGES

Product certification

KNX members can only bring KNX products on the market via the KNX product certification procedure, which means that the use of the KNX logo for a device is only granted after a successful certification procedure. The KNX logo printed on each KNX device assures us of at least four aspects:

Quality

One of the prerequisites in order to apply for product certification; is for the KNX member to be ISO 9001 compliant. This means that the KNX member needs to have a quality control system installed within its organisation. Such quality control system will obviously have a positive influence on the quality and reliability of the KNX products manufactured by that KNX member.

Runtime compatibility

One part of the certification tests is to assure the compatibility of the product under test. The result is manufacturer independence: devices and applications of different manufacturers can be combined in an installation in any way and will wherever meaningful be able to communicate and understand each other.

Configuration compatibility

Another part of the certification tests is to assure the configuration compatibility of the product. The result is that only one tool is required: i.e. any KNX device from any manufacturer can be configured with the KNX Engineering Tool Software, also known as 'ETS'.

Backwards compatibility

KNX is and always will be backwards compatible: this means that e.g. 20 year old installations can still be extended/equipped with KNX devices brought to the market today. It also means that today's installations can be extended with any KNX device brought on the market in the future.

Saving energy

Building events

Since the very beginning of KNX it is possible to adapt building loads automatically based on events occurring inside the building itself.

Example 1 - window contacts: i.e. the bus system of a building can 'know' whether a window is open or closed. Now imagine an office building where the heating is set to comfort mode, if at the same time someone opens a window in one of the rooms of that building, then its installation can detect this conflict and set the heating to e.g. economy mode in the room or in the zone where the open window was detected.

Example 2 - presence detection: the bus system of a building can 'know' whether someone is present in a room, this will make it possible to only illuminate those rooms where also someone is really present.

Smart grids

KNX contributes to the Smart Grid concept: in the near future the connection between the electrical installation of a building and the energy provider will be extended with ICT, i.e. there will be an information flow in two directions: the information exchange from the provider to the building, is about the tariff of the energy supplied valid for that very time interval. The exchanged information in the other direction, is about the actual energy consumption of the building during that very time interval.

This concept will make it possible to adapt building loads automatically based on tariff. E.g. switch off loads with lower priority when the energy, tariff reaches a particular price level. This does as such not necessarily directly reduce our consumption of energy, but it will at least stimulate us e.g. to postpone the consumption of energy for lower priority loads till (more) renewable energy is available. Result: reduced energy costs.

Making combinations

Building application types

With KNX it is possible to combine within one installation all types of building functions, like: lighting, shutters/blinds, HVAC, metering, energy management, audio/video, white goods, access control, fire/smoke detection, physical sensors (e.g. water) etc.

Communication media

First of all, KNX supports four different communication media, they all serve a specific purpose or use case:

TP | Twisted Pair

Is the most common used solution, because of its simplicity in order to set it up (free topology, no network terminators required,...).

PL | Powerline

Which allows KNX devices to communicate over 230 V mains wires. This is often the preferred solution for renovations.

IP

Typically used as a fast and reliable backbone between several TP based segments of a KNX installation, this certainly can be very important for bigger installations.

RF | Radio Frequency

Allows KNX devices to communicate over radio signals, where no cable (TP, IP or PL) is available or cannot be installed.

Second: all four communication media can be combined within one and the same KNX installation. In order to link two different communication media, a so called 'KNX Media Coupler' is required: a few examples of possible combinations are (primary medium/secondary medium): TP/RF, TP/PL, IP/TP.

Decentralised bus system

This means that the entire functionality of the installation is divided over the individual bus devices that form together the installation, or in other words: each individual bus device is 'only' informed about its own specific role within the installation.

This concept makes the flexibility aspect of KNX installations complete: changing, adding or removing devices has only a minor influence on the composite installation functionality.

Centralised bus systems have a central unit that controls the entire installation. The disadvantage is the complete lack of flexibility: a problem with the central unit will effect the entire installation, in worst case the entire installation simply stops working. Or even just updating the central unit could in worst case compromise the entire installation.

Yet, though KNX does not require any central component, central functions are possible, like one or more central visualisations, schedulers, a central clock, management stations etc.

Appendix

This publication 'only' explained the KNX system principles. We recommend to read the 'KNX Basics' flyer, the 'KNX Handbook' and to use the KNX eCampus platform, which is accessible via your 'My KNX' account, in order to understand what happens live in a KNX installation, or in other words in case you are interested in the bits and the bytes.



Smart home and building solutions.
Global. Secure. Connected.



Join **us**
www.knx.org